

RAIN/STORMWATER - TANK FILL CONTROLLER w/ 10m Float Switch

FEATURES:

- Automatic 'Tank Full' pump inhibitor
- 'Tank Full' indicator light
- Low voltage Float Switch circuitry
- Rated for pumps up to 8Amps
- Weatherproof polycarbonate enclosure
- 'Quick Plug' power/pump connections

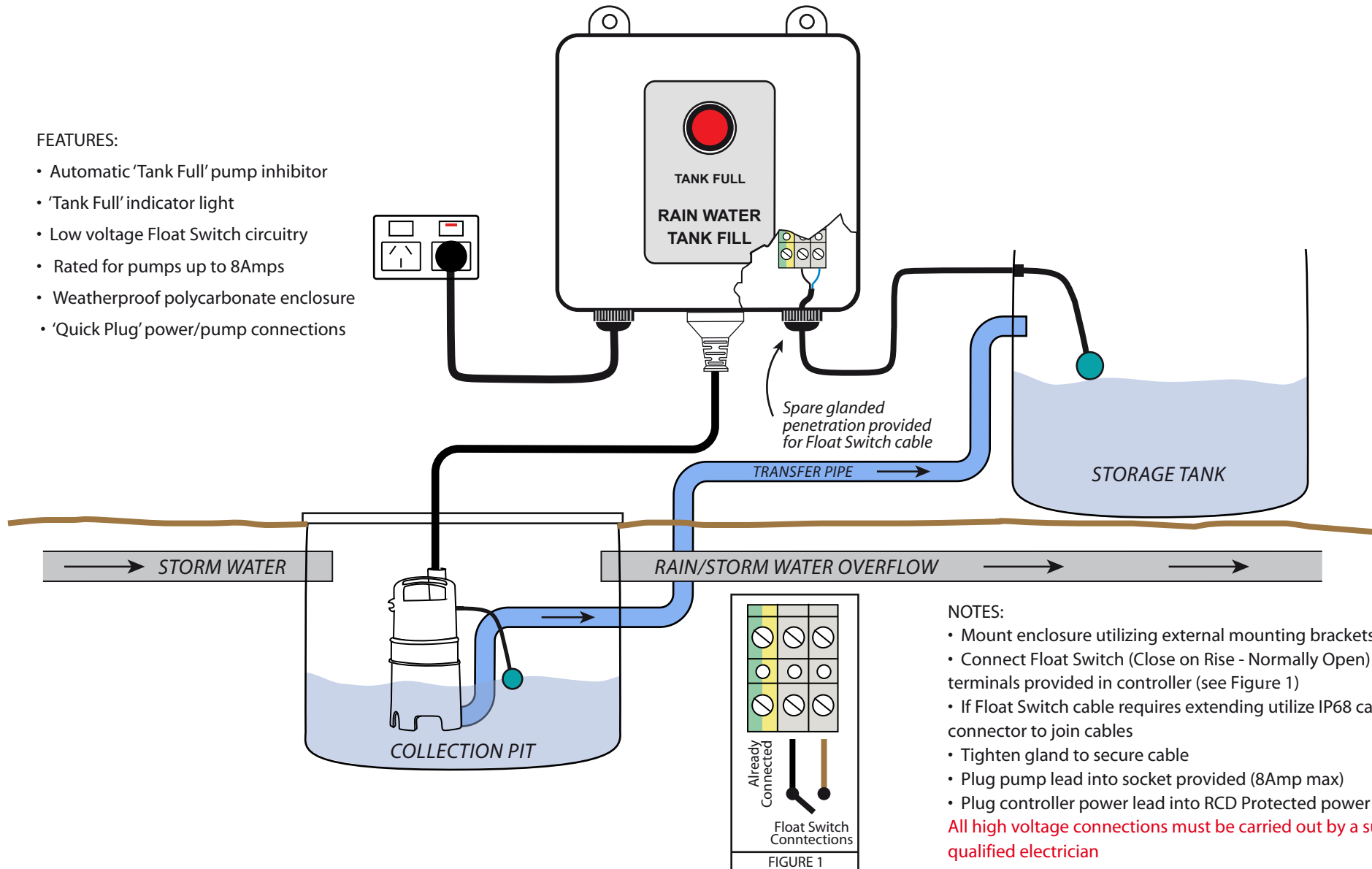

NOTES:

- Mount enclosure utilizing external mounting brackets
 - Connect Float Switch (Close on Rise - Normally Open) to terminals provided in controller (see Figure 1)
 - If Float Switch cable requires extending utilize IP68 cable connector to join cables
 - Tighten gland to secure cable
 - Plug pump lead into socket provided (8Amp max)
 - Plug controller power lead into RCD Protected power point
- All high voltage connections must be carried out by a suitably qualified electrician**