

UV-C POND BIO PRESS FILTER

F5000PP/F10000PP/F15000PP

Instruction Manual



 **PondPro®**

INSTRUCTION FOR USE

Use these instructions to familiarise yourself with the device before you use it for the first time. It is imperative that you observe the safety guidelines on the proper and safe use of this device. For safety reasons, children and young people under 16 years of age, as well as people who can not recognize potential hazards or who are not familiar with these instructions, must not use the device. Please keep these instructions in a safe place! In the event of a change of ownership, please pass these instructions on to the new owner along with the product.



SYMBOLS



Water go through the pump into the filter.



Water go through the filter into the pond.



Water from the cleaning outlet go into the sewerage system or flower bed, etc.

UNPACKING

When unpacking, if external damage is visible which could impact the functioning of important parts of the equipment, please inform the carrier of the defects immediately, on the same day if possible, and insist on the facts being recorded in writing. then contact your supplier who will take care of everything else.



APPROPRIATE

The pressure filter with integrated UV is sealed pressure filter system for biological and mechanical filtering of normal pond water with a temperature of +4°C to 35 °C. this pressure filter is exclusively intended for private use for cleaning garden ponds with or without pond fish. Never filter liquids other than water.



SAFETY GUIDELINES

- 1、 Electrical installation must be in accordance with the provisions of the domestic.
- 2、 Extension cable and adapter (such as socket board) must be suitable for outdoor use (To prevent water splashing).
- 3、 Make sure that the filter UV is equipment with a measured fault current not greater than 30mA visa a fault current protection switch(FI or RCD).
- 4、 Power supply connection section of the wire shall not be lower than with abbreviated symbol H05RN – F rubber cable.
- 5、 If problems or difficulties, please seek help from electrical professionals



- 6、 The electrical data of the supply must correspond to the data on the lable.
- 7、 Dangerous ultraviolet radiation, the rays from the UV lamp are harmful to your eyes and skin! Never operated the lamp outside the casing.
- 8、 If the connecting cable, UV lamp or there is any breakage on the shell, may not run this product.
- 9、 If someone in water, can not run this product.
- 10、 In addition to the clear requirements on the manual, can not open the equipment or other accessories.
- 11、 Before any operation on the equipment, should cut off all the power of the equipment.
- 12、 Equipment, the interface and the plug is not waterproof, so do not allow the underwater laid or installation.
- 13、 keep dry.
- 14、 Need a pump to run this product. The maximum head of the pump shall not be longer than 0.6 bar (6 m head).
- 15、 This product internal pressure shall not exceed 0.2 bar (function switch between red buoy up for internal Pressure is greater than 0.2 bar).
- 16、 Hoses that connection the filter and pump must can withstand the pressure greater than 0.2 bar or the maximum head of the pump.
- 17、 In the product normal work should ensure function switch to "filter". Only when cleaning, allows the switch to "clean".
- 18、 Before starting up the filter, check the connected hoses, the clamp with safety latch are correctly.
- 19、 If it is a frost day, you have to remove the filter.
- 20、 Install the filter where it will not be exposed to direct sunlight.



HOW THE FILTER WORKS

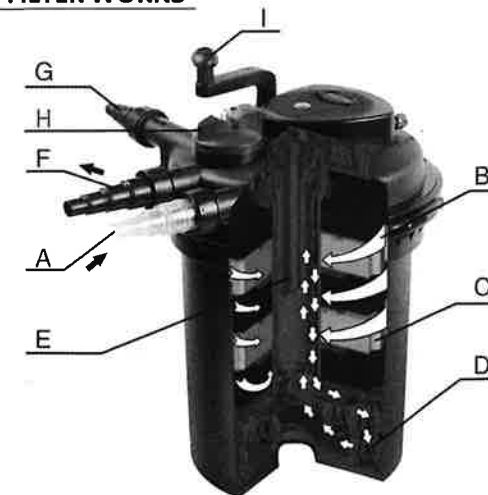



The pressure filter with integrated UV is a sealed filter system for the biological and mechanical cleaning of pond water.

A、 water inlet

The pump is connected to the water inlet with a pressure hose.

B、 vortex system

Under the action of gravity, suspended solids and mud are separated.

C、 mechanical filter

When the water through the filter sponge into the internal , dirt particles will be stopped by filtering sponge surface.

D、 Biological clarifying

The pores of the filter sponge from a large inner surface which microorganisms can colonize .The yellow and blue filter sponges differ in size and density. This creates zones in which the water can flow at different speeds. Zones with a high flow speed(blue filter sponges) favour the colonization of microorganisms which convert ammonium to nitrate via nitride(nitrification). Zones with a low flow speed (yellow sponges) support the colonization of anaerobic microorganisms which reduce nitrate to nitrogen(denitrification).

E、 Clarify the pond water

As the water flow out , it is briefly exposed to ultraviolet radiation under the UV lamp .This kill off germs and bacteria and inhibits algae growth .

The water subsequently flow from the edge into the filter in a circular fashion.

F、 water outlet with flow indicator

At the water outlet, the clarified water is fed back into the garden pond via pressure hose or a watercourse etc.

G、 cleaning connection

When cleaning the filter, a drainage hose can be connected to the cleaning connection which diverts the dirty water into the sewerage system or onto a flower bed.

H、 function switch

The function switch is used to switch between normal water discharge into the pond "filter" and the cleaning connection "clean".

I、 cleaning the filter sponges with the handle function

The filter sponges can be cleaned by turning around the cleaning handle.

Definition of clear water

Clear water is achieved if the fish or stones at the bottom of the pond can be seen at a depth of 1m.

The installation of the filter

1、 Install the filter so that it is safe from flooding. Secure your filter so that will not fall into the pond. it should be placed at least 2 m from the edge of the pond.

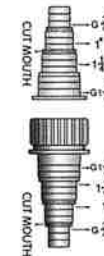
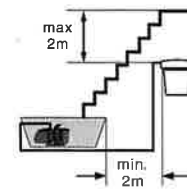

- 2、 Dig a hole beside the pond, bedded filters below Clamp. Or put the filter in a strong smooth place.
- 3、 In order to facilitate work on filter, installed to ensure that the lid can open.
- 4、 Pumping height (the vertical height of the outlet to the pond water), more than 1 m to choose a correspondingly more powerful pump.

Connecting hoses

we recommend warming the hose with hot water, pushing it onto the spiral stepped hose adapter and securing it with a hose clip. This makes the connection more watertight.

- 1、 Try to choose larger diameter hose to connect the filter.
- 2、 For hoses that are longer than 4 m , please always use hoses that correspond to the upper value of the scale.
- 3、 In order to avoid pressure loss, cut the spiral stepped hose adapter at the relevant points for each hose.

cleaning connection

Connected to the cleaning connection. This allows you to drain the dirty water directly into the sewerage system or onto a flower bed.

Starting on the pressure filter

Before each start-up, you should check that the connected hoses, the sealing cap and the clamp with safety latch are sitting correctly. the function switch must be set to the "filter" symbol. It is imperative that you read and follow the safety guidelines before start-up.

- 1、 Switch on the pump. Caution! The UV lamp must not be operated without water flowing it.
 - 2、 Check all the sealing connection, If there is leaking, it should be adjusted.
 - 3、 Pass filter on the power supply.
 - 4、 The filter system with integrated UV must be running permanently, 24 hours a day.
 - 5、 The UV lamp must be replaced after 8,000 hours of operation in order to ensure that the filter UV continues to operate with optimum effectiveness.
 - 6、 The filter system must be cleaned regularly.
- Attention: in the case of a new installation, the pressure filter only reaches its full biological cleaning effectiveness after a few weeks. Extensive bacterial activity only starts at temperature of +10°C or above.

Washing the filter sponges

Suspended matter and dirt are deposited in the filter sponges over time. These deposits reduce the effectiveness of the filter, so the filter sponges should be cleaned regularly, e.g. Every week.

The filter sponges should be cleaned when cloudy or even dirty water flows out of the water outlet and back into the pond. (When the red indicators which in the handle function is float on.)

- 1、 Turn clockwise until it clicks into the "clean" position.
- 2、 Circumgyrate cleaning handle hard and several times. This squeezes the filter sponges and cleans them mechanically. Circumgyrate for deasil and at will achieve a better results.
- 3、 The filter now will be rinsed .Once clean water could be seen through the transparent spiral stepped hose adapter at the cleaning connection, turn anti-clockwise until it clicks into the "filter" position.
- 4、 The filter is now operating again. Check the water flow into the pond.

Replacement of the filter sponges

If the water flow is too small due to dirty filter sponges and can not be improved through cleaning with the handle function. The filter sponges must be washed or replaced.

Please do not use any chemical cleaning agents so as not to kill off the microorganisms in the filter sponges.

- 1、 Disconnect the mains plug of the filter.
- 2、 Switch off the pump and ensure that it cannot be switched on unintentionally, remove all hoses by unscrewing the union nuts.
- 3、 Remove protective buckle, then open the clamp.
- 4、 Lift off the lid with the filter sponge assembly. Place the lid upside down on another clean surface. The filter sponges are lying with filter plat facing up.
- 5、 Remove the diversion pipe anticlockwise, remove the screws on the gear and the separate plate.
- 6、 Remove the filter sponges to replace or clean.
- 7、 Pull off the filter sponges part and clean them under flowing water. Give the filter sponges a good squeeze.
- 8、 Clean the container, filter sponges, O-ring and the edge of the container by spraying them with a water hose.
- 9、 Put the sponge part as follow, put on the separate plate, fixed cleanness gear set, fasten the diversion pipe.
- 10、 Place the O-ring 3 onto the upper edge of the container. (In order to easy to fit you should make it wet). press down on the lid.
- 11、 Put the clamp on the right place. Push the safety latch in.

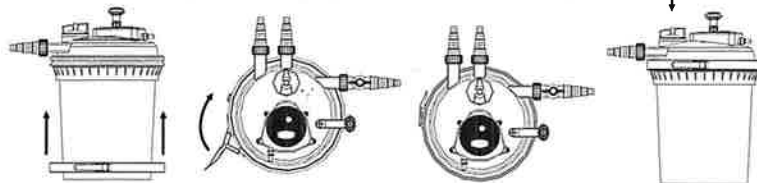

- 12、 Fasten all hoses with flat seals or flow vane to the corresponding connection by screwing the union nuts on tight.
- 13、 Start the pressure filter up again.

Cleaning the quartz tube and replace the UV lamp

- 1、 Unscrew the four screw on the lid.
- 2、 Pull out of the light head, then you can clean the quartz glass tube.
- 3、 Clean the quartz glass tube with wet cloth.
- 4、 Remove the fixing-nut on the quartz glass tube.
- 5、 Pull out of the quartz glass tube then you can replace the UV lamp.
- 6、 Check the quartz glass tube set, change it if broken.
- 7、 Set up all part of the filter as before and start up the filter again.

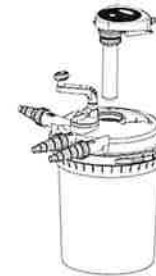

Criteria: pond size and with /without fish population).

PUMP FLOW		3000L/h	4000L/h	6000L/h	8000L/h	10000L/h
CPF-5000		2m³	2.5m³	3m³	4m³	/
		4m³	5m³	6m³	8m³	/
CPF-10000		/	3m³	4m³	5m³	6m³
		/	6m³	8m³	10m³	12m³
CPF-15000		/	4m³	6m³	10m³	15m³
		/	8m³	12m³	20m³	30m³

TROUBLESHOOTING

FAULT	POSSIBLE REASON	MEASURES
Water not getting clear	<ol style="list-style-type: none"> 1、 Unit not been used for long. 2、 Inappropriate pump capacity. 3、 water is extremely dirty. 4、 Fish and animal population is too much. 5、 Filter sponges are dirty. 6、 Quartz glass tube is dirty. 	<ol style="list-style-type: none"> 1、 Full effectiveness of biological cleaning is only reached after a few weeks. 2、 Reset the power of the pump. 3、 Remove algae and leaves from the pond, or change the water. 4、 Guideline: approx 1Kg fish to every 1000 cbm of pond water. 5、 Clean the filter sponges. 6、 Clean the quartz glass tube .

UV lamp indicator is not on	<ol style="list-style-type: none"> 1、 Main plug of filter UV not connected. 2、 Defective UV lamp. 3、 Faulty connection. 4、 The filter is over heating. 	<ol style="list-style-type: none"> 1、 Connect the mains plug of the filter. 2、 Replace the UV lamp. 3、 Check the electrical connection. 4、 UV switched on automatically after cooling down.
No water discharge from pond inlet	<ol style="list-style-type: none"> 1、 Function switch set to "clean" . 2、 Mains plug of the pump is not connected. 3、 Pond inlet blocked. 	<ol style="list-style-type: none"> 1、 Reset function switch to "filter" . 2、 Connect the mains plug of the pump. 3、 Clean the inlet of pond.

Wearing parts

- 1、 UV tube
- 2、 Filter sponges
- 3、 Seal set

Part list

No.	Name	No.	Name	No.	Name
1	UV head	10	Separate plate	19	Shaft connection
2	O-ring 1	11	Diversion pipe	20	Upper bearing
3	Sleeve	12	Filter basket cover	21	Gasket
4	UV lamp	13	Bio-ball	22	Inlet&Outlet
5	O-ring 2	14	Filter basket	23	Inlet&Outlet nut
6	Quartz glass tube set	15	Clamp	24	Clean gear set
7	Fixing-nut	16	O-ring 3	25	Down bearing
8	Lid	17	Container	26	Washer
9	Sponge	18	Cleaning handle	27	Screw

PART LIST

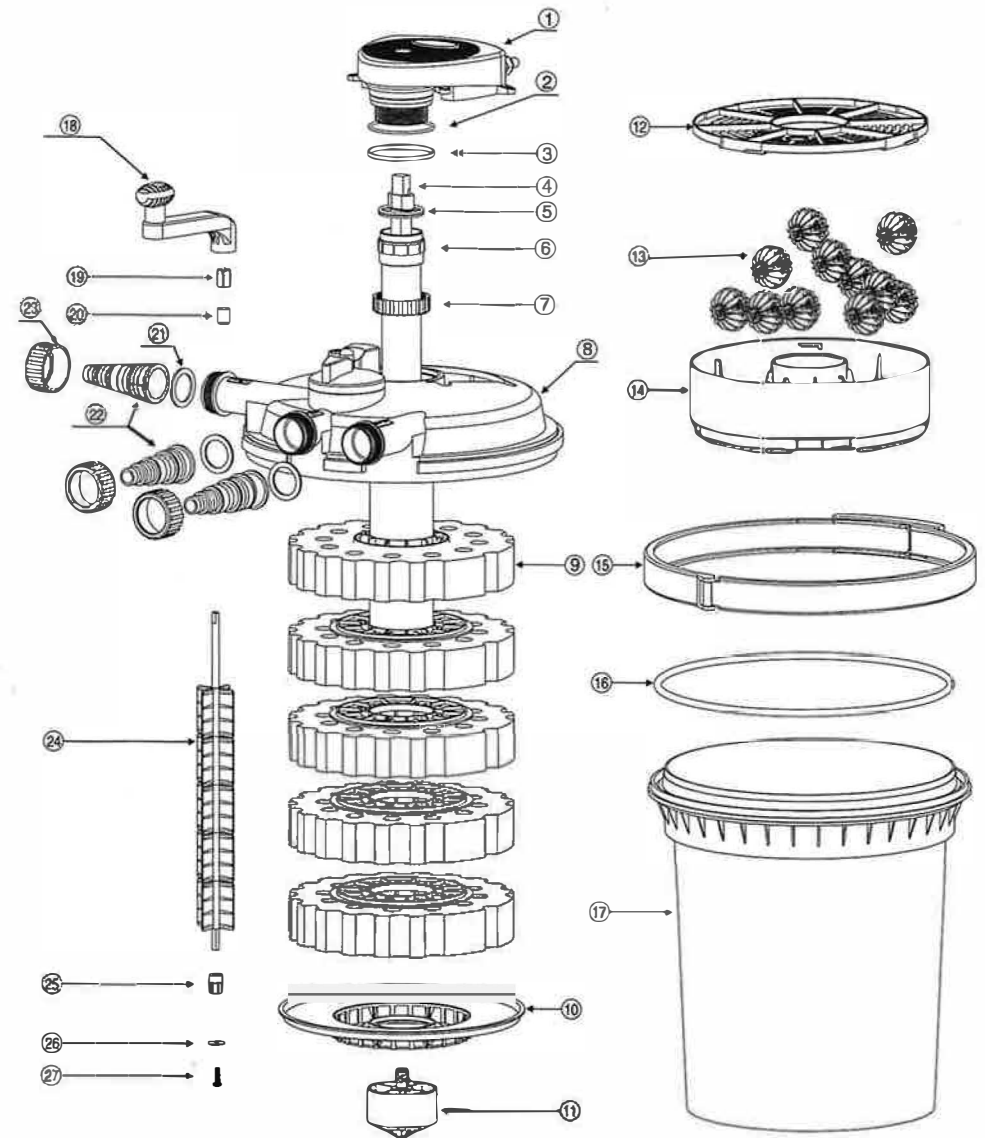

The Register Of Water Quality Test

Date	Temperature	Water color	Ph	CO ₃ ²⁻	Total hardness	NH ₃ /NH ₄	NO ₂ ⁻

Warranty Registration Form
You Must Fill In All For Warranty Validation.

WARRANTY CARD

Model No		Date of purchase	
User		Address	
Zipcode		Phone	Contact person
Retailer			
Maintenance Records			
Y M D			

Note: This warranty card is for further quality information from you and timely service from our company.

- 1、 This card is to ensure quality service for product of our company.
- 2、 The warranty term is 2 years, valid from the date of purchase filled on this card.
- 3、 The lamp and other damageable parts are not in the time of guarantee.
- 4、 The damage caused by incorrect use or the contrived will be exempted.

WARRANTY CARD (leaf For Retailer)

Model No		Date of purchase	
User		Address	
Zipcode		Phone	Contact person
Retailer			

