

REEFE rainpro®

REEFE External Pump System with RainPro RM4000-3 Rain to Mains Backup Valveset Installation Guide & Owners Information

MODELS: RM4000-3, RM6000-3, RM7000-3, RC450-3, RC750-3, RM4058

**** Please leave this guide in a safe place for the owner ****

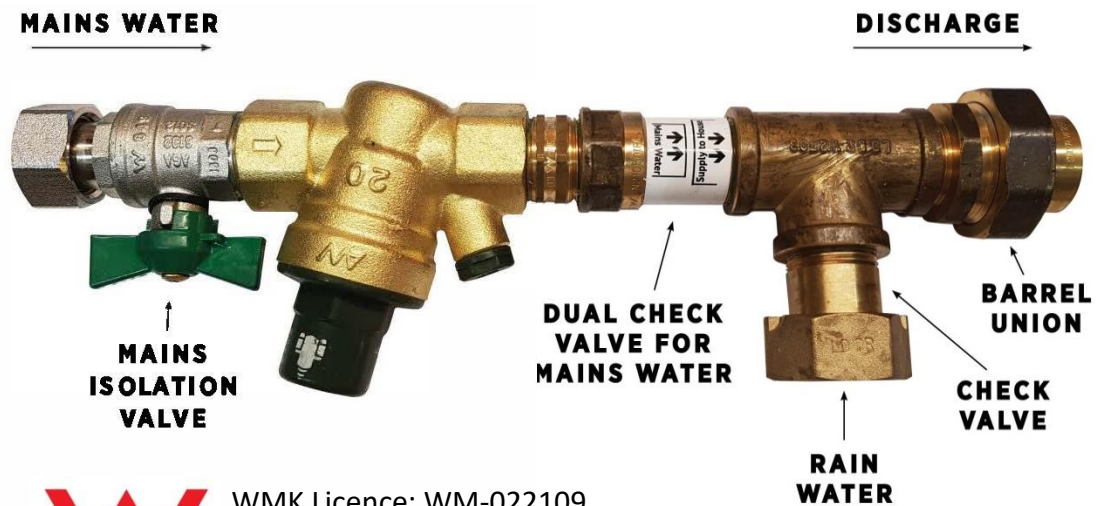

WMK Licence: WM-022109

WaterMark

Australian Standard: WMTS-477

*** BARREL UNION & BALL-VALVE NOT FITTED TO ALL VERSIONS**

IMPORTANT INFORMATION

MANDATORY INSTALLATION CONDITION: THE PREMISES WHERE THE PUMP IS INSTALLED MUST BE PROTECTED BY AN RCD (SAFETY SWITCH) – DO NOT INSTALL PUMPS WITHOUT THIS PROTECTION

- All parts shown are WaterMarked & certified for Potable Water
- Fittings may differ from the image shown
- Do not adjust the PRV, warranty is void if adjusted
- Flooded suction only, no suction lift unless a float switch is added in the rainwater tank
- A Y-Strainer or Pre-filter **MUST** be installed in the suction pipe between the rainwater tank and the pump – warranty is void if this is not fitted
- Read and follow the instructions in the pages following

IMPORTANT: if installing close to a wall or other fixture, use barrel-union connections to allow removal if ever required.

CORRECT INSTALLATIONS - EXTERNAL PUMPS

IMPORTANT!

FLOODED SUCTION ONLY! THE TANK WATER MUST BE "GRAVITY FED" TO THE PUMP. THE SYSTEM **WILL NOT** FUNCTION CORRECTLY WITH SUCTION LIFT.

CONDITION OF WARRANTY

All installations must include:

- (1) BARREL UNION
- (2) Y-STRAINER OR PRE-FILTER
- (3) BALL VALVE OR GATE VALVE

MAX MAINS PRESSURE 500KPA

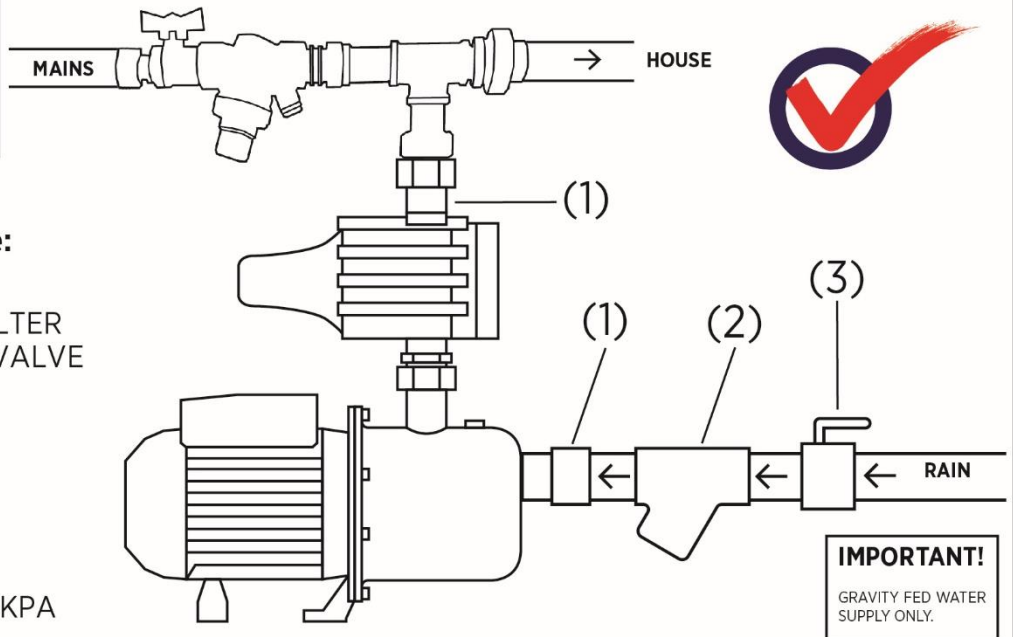

IMPORTANT!
GRAVITY FED WATER SUPPLY ONLY.

INCORRECT INSTALLATIONS

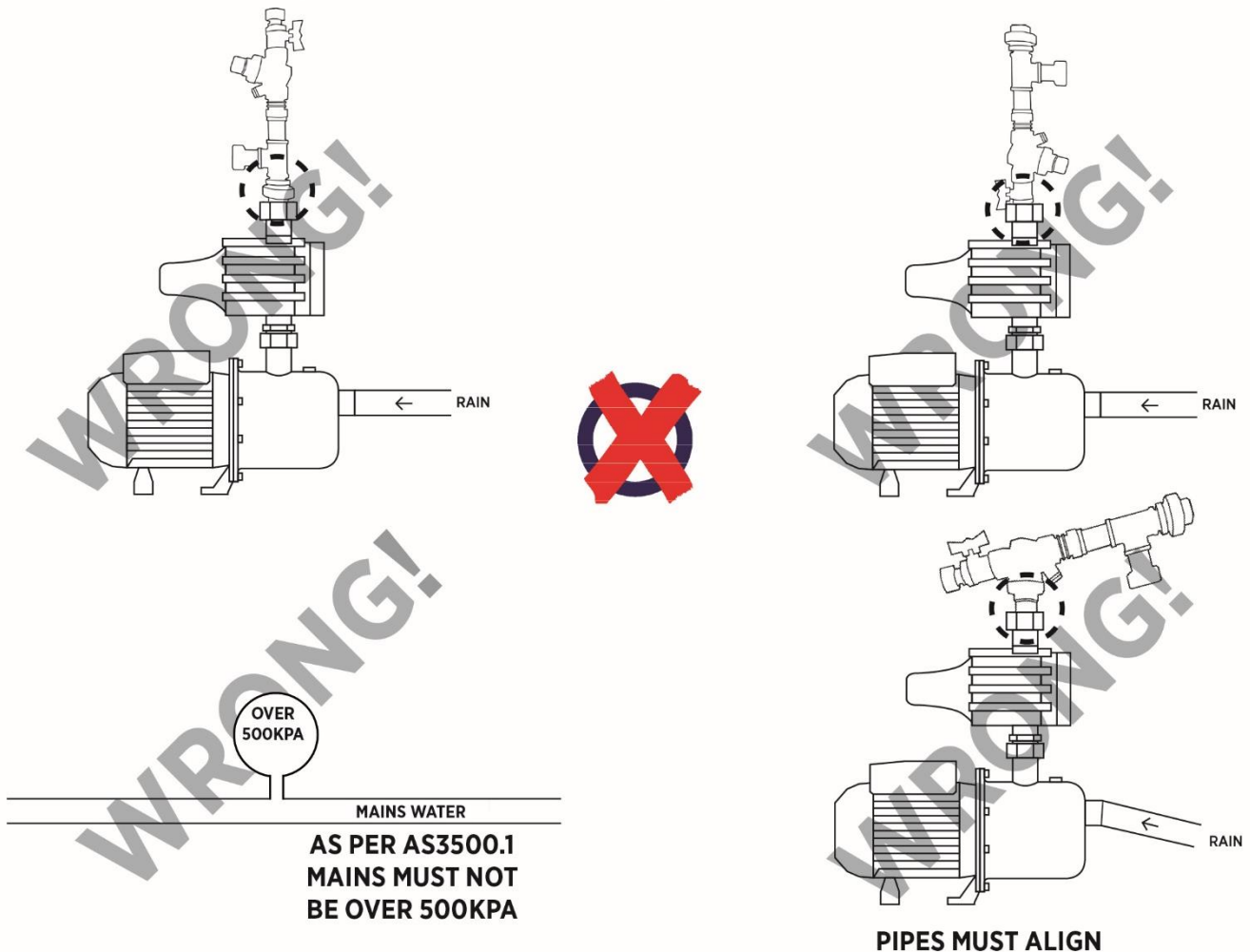

CORRECT INSTALLATION - EXTERNAL PUMPS

Tank Outlet must be at same level as pump inlet



FLOODED SUCTION

IMPORTANT
Have suction pipe straight to pump.
Do NOT loop underground

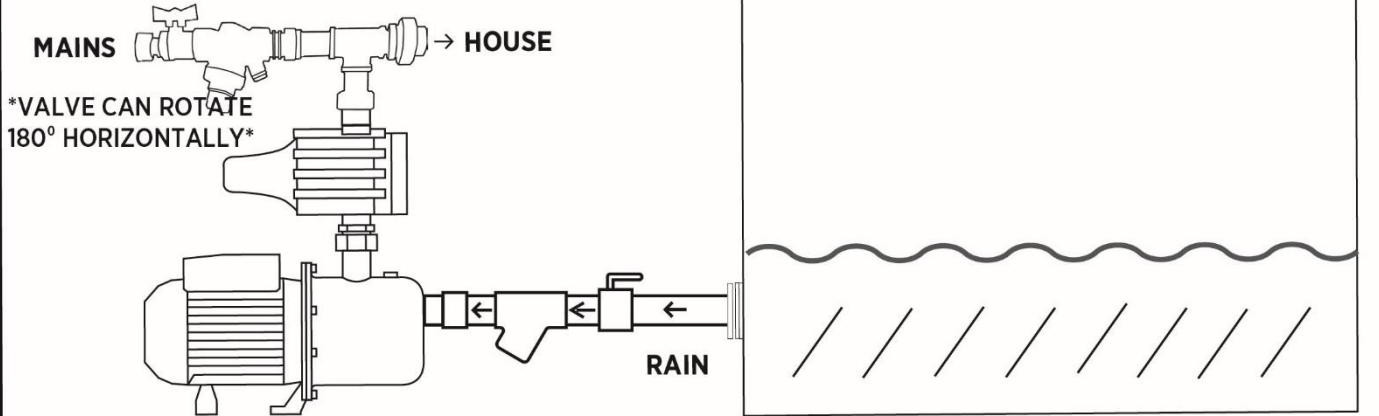

INCORRECT INSTALLATIONS

⚠ INCORRECT! PIPES TOO SMALL!

FOR PUMP INLET, USE 25mm PIPE (INTERNAL DIAMETER). WE RECOMMEND 30mm FOR BEST PERFORMANCE. (FOR PUMPS WITH 32MM INTAKE OR LARGER, USE SUCTION PIPE ONE OR MORE SIZE LARGER).

For the outlet (discharge) pipework, use pipe that is the same diameter as the outlet of the pump, or NO MORE THAN ONE SIZE SMALLER. **BIGGER PIPE = BETTER PERFORMANCE**

PLEASE READ THE INSTRUCTIONS FOR MORE DETAILED INSTALL INFORMATION.

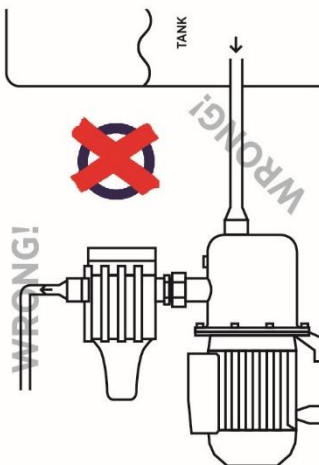

IMPORTANT

FOR VERY LONG SUCTION/INTAKE PIPEWORK, IT IS CRITICAL THAT THE CORRECT PIPE SIZE IS USED ESPECIALLY IN SUCTION-LIFT APPLICATIONS, CHECK WITH A QUALIFIED PUMP TECHNICIAN FOR THIS TYPE OF INSTALLATION.

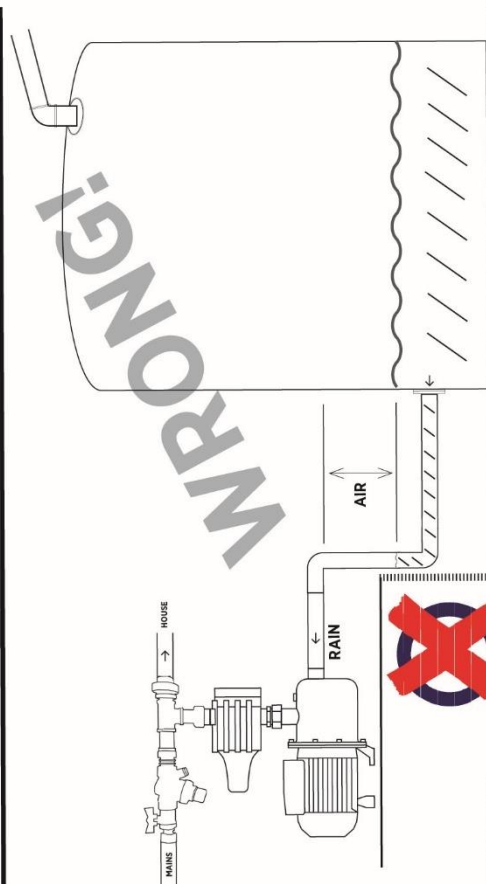

INCORRECT

The pump will not automatically re-start. It cannot suck the air out of the pipe work. It will only restart when the water level is above the pump level.

RESOLUTION

You must fit a foot valve inside the tank or a check valve on the outlet AND fit a pump shut-off controller, code 12983.

(The best option in this situation is to use the Submersible Pump System RM5000)

CORRECT INSTALLATIONS

ALWAYS INSTALL YOUR PUMP ON A LEVEL CONCRETE OR PAVED SURFACE!

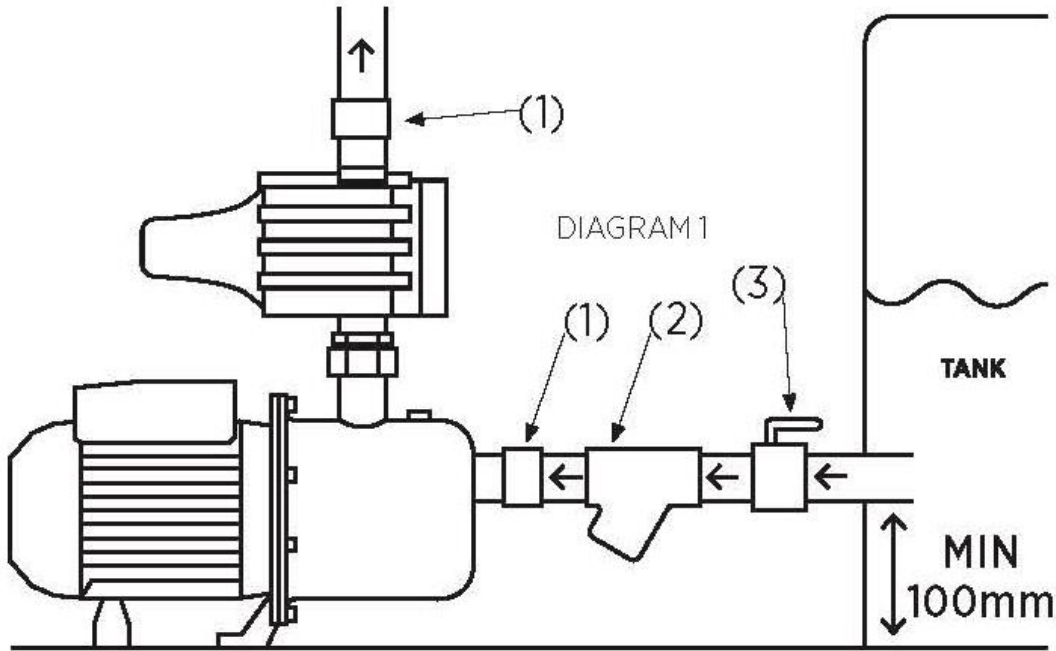

TIP!
PRESSURE TANKS
CAN SAVE YOU
MONEY AS THE
PUMP DOES NOT
HAVE TO START SO
OFTEN.

CONDITION OF WARRANTY: All installations must include;

- (1) BARREL UNION
- (2) Y-STRAINER OR PRE-FILTER
- (3) BALL VALVE OR GATE VALVE

TIP! CLEAN THE Y-STRAINER MONTHLY TO ENSURE PEAK PERFORMANCE. SIMPLY UNDO THE BUNG AND LET IT FLUSH OUT. MAKE SURE YOU RE-FIT THE MESH FILTER.

TIP! IF PUMP STARTS FREQUENTLY, CHECK TOILET CISTERNS, THEY ARE PROBABLY LEAKING.

IMPORTANT! RAIN-MAINS SYSTEMS ARE NOT TO BE USED WITH SUCTION LIFT UNLESS A PUMP SHUT-OFF CONTROLLER IS ADDED

IMPORTANT!

ALWAYS PRIME
THE PUMP BEFORE
STARTING.

DIAGRAM 10

TIP
SOMETIMES YOU MAY
HAVE TO DO THIS
AFTER THE PUMP HAS
STOPPED DUE TO THE
TANK BEING EMPTY
OR LOW IN WATER.

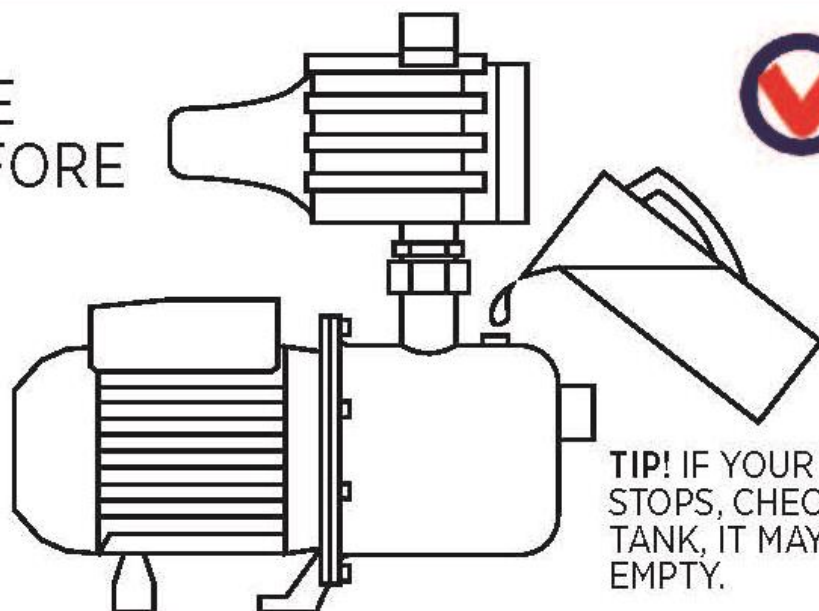

TIP! IF YOUR PUMP
STOPS, CHECK YOUR
TANK, IT MAY BE
EMPTY.



INCORRECT! THE PUMP IS CONNECTED INCORRECTLY. ALWAYS ENSURE WATER INLET AND OUTLET ARE CORRECT.

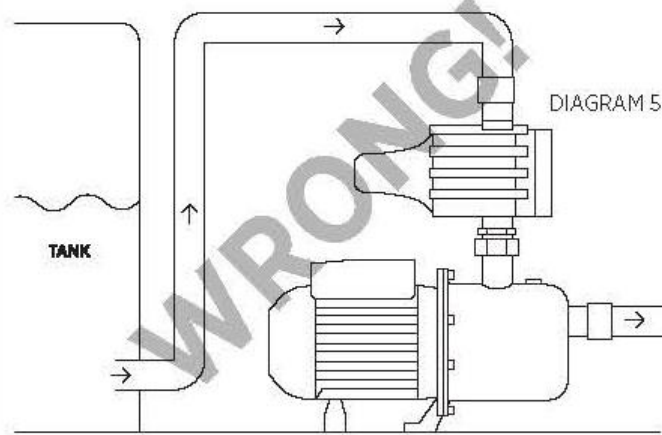

INCORRECT! PUMP IS NOT INSTALLED ON A LEVEL SURFACE. ALWAYS ENSURE THE PUMP IS INSTALLED LEVEL.

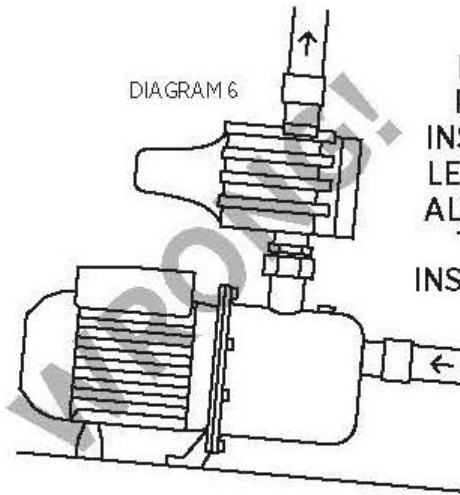
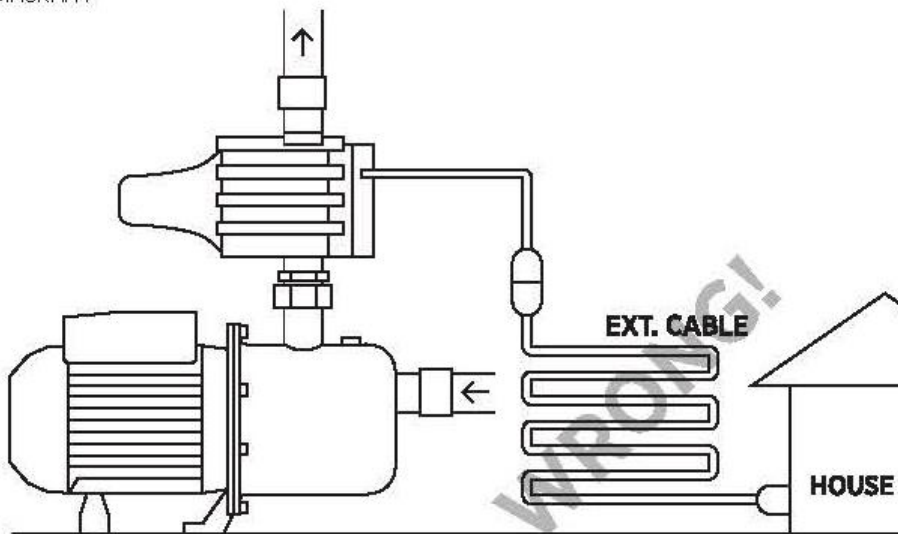

DIAGRAM 7



INCORRECT! DON'T USE EXTENSION LEADS.

NEVER USE AN EXTENSION CABLE TO CONNECT THE PUMP TO MAINS POWER.

ALWAYS CONNECT PUMP DIRECTLY TO DEDICATED POWER OUTLET.

DIAGRAM 8

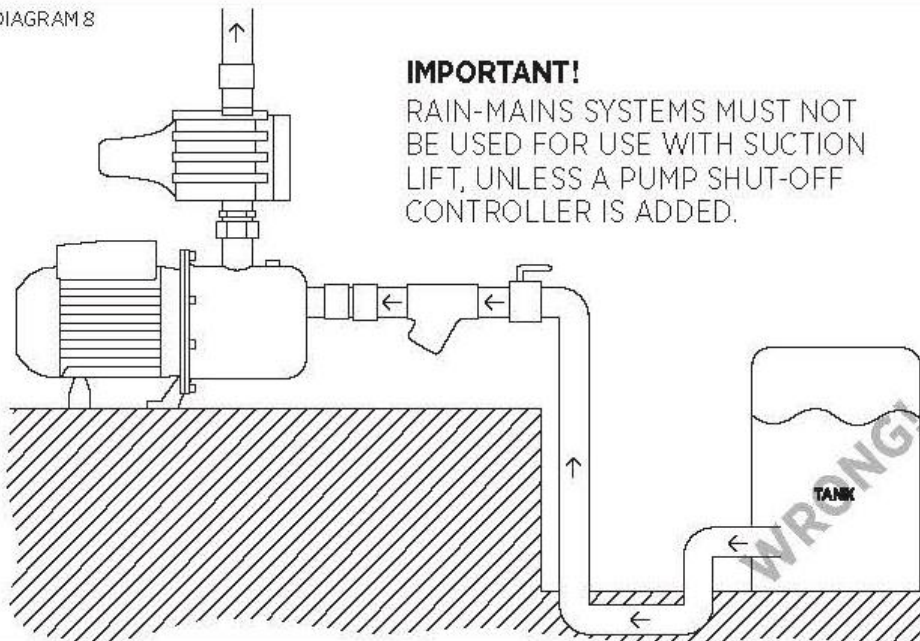

IMPORTANT!

RAIN-MAINS SYSTEMS MUST NOT BE USED FOR USE WITH SUCTION LIFT, UNLESS A PUMP SHUT-OFF CONTROLLER IS ADDED.



INCORRECT! NO FOOT VALVE!

FOR INSTALLATIONS WHERE THE PUMP IS ABOVE THE OUTLET OF THE TANK, ALWAYS USE A FOOT VALVE IN THE TANK, OR A SWING-CHECK VALVE IF VIABLE.

DIAGRAM 9

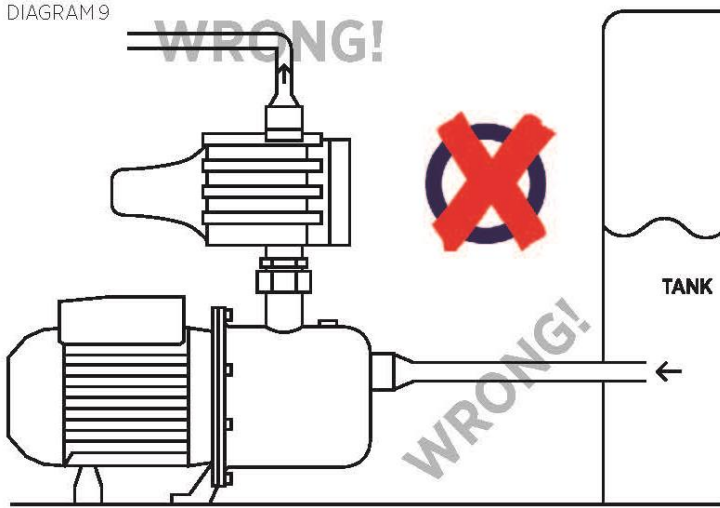

INCORRECT! PIPES TOO SMALL!

FOR PUMP INLET, USE 25mm PIPE (INTERNAL DIAMETER). WE RECOMMEND 30mm FOR BEST PERFORMANCE. (FOR PUMPS WITH 32MM INTAKE OR LARGER, USE SUCTION PIPE ONE OR MORE SIZE LARGER).

For the outlet (discharge) pipework, use pipe that is the same diameter as the outlet of the pump, or NO MORE THAN ONE SIZE SMALLER. **BIGGER PIPE = BETTER PERFORMANCE**

PLEASE READ THE INSTRUCTIONS FOR MORE DETAILED INSTALL INFORMATION.

IMPORTANT

FOR VERY LONG SUCTION/INTAKE PIPEWORK, IT IS CRITICAL THAT THE CORRECT PIPE SIZE IS USED ESPECIALLY IN SUCTION-LIFT APPLICATIONS, CHECK WITH A QUALIFIED PUMP TECHNICIAN FOR THIS TYPE OF INSTALLATION.

INCORRECT INSTALLATIONS



INCORRECT! PUMP IS INSTALLED WITHOUT BARREL UNION'S, A Y-STRAINER & A BALL VALVE.

DIAGRAM 3

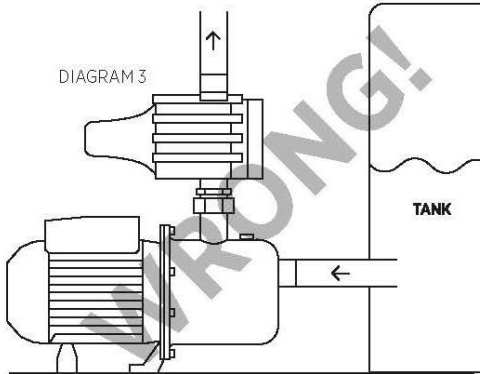

INCORRECT! PUMP IS INSTALLED WITHOUT A CHECKVALVE OR A FOOT VALVE.

DIAGRAM 4

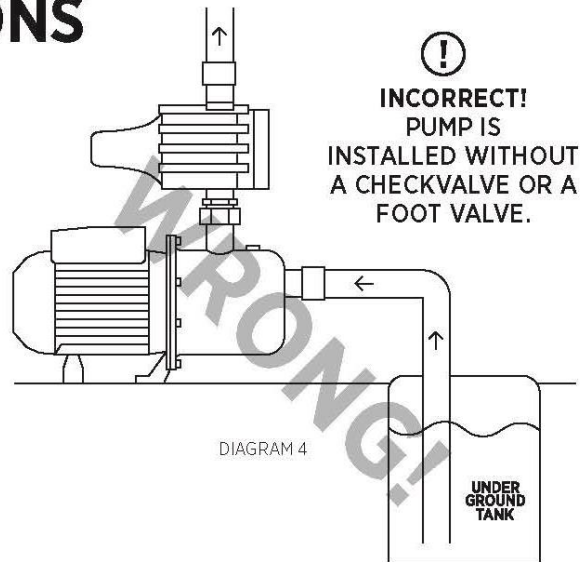

DANGER!

ALWAYS DISCONNECT THE PUMP FROM POWER WHEN INSTALLING, AND WHILE SERVICING OR REPAIRING.

DIAGRAM 11

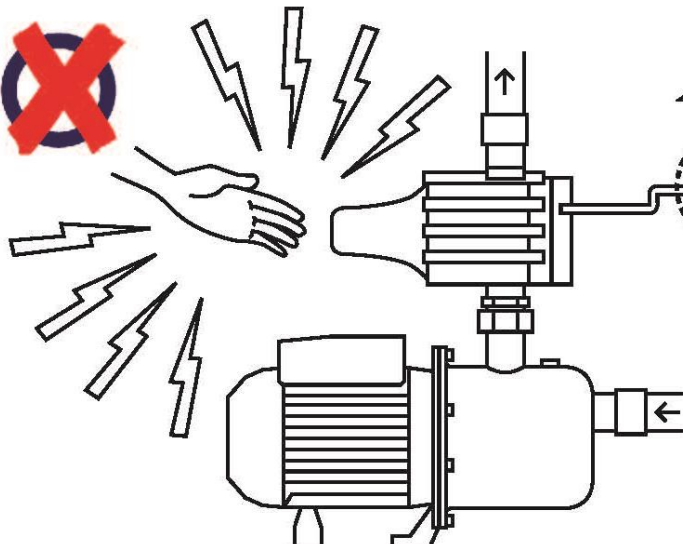

DANGER!

ENSURE THE PUMP IS CONNECTED TO A POWER OUTLET THAT IS PROTECTED BY A SAFETY SWITCH (RCD). IT IS BEST PRACTICE TO HAVE A DEDICATED CIRCUIT.

DIAGRAM 12

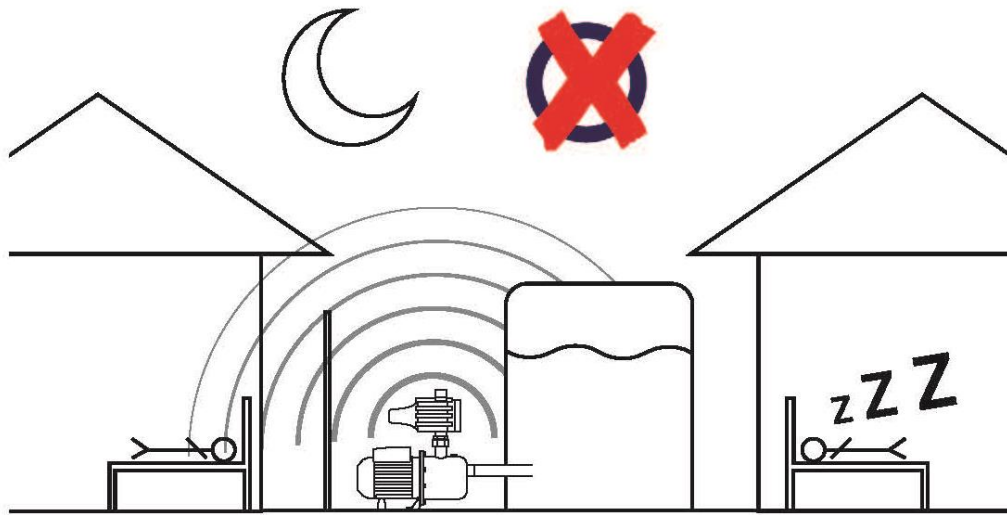

IMPORTANT

CONSIDER NEIGHBOURS WHEN INSTALLING THE PUMP. ALL PUMPS MAKE SOME NOISE.

DIAGRAM 13

IMPORTANT - DO NOT EXPOSE THE PUMP DIRECTLY TO THE ELEMENTS. WE RECOMMEND THE PUMP IS PROTECTED WITH A PUMP COVER.

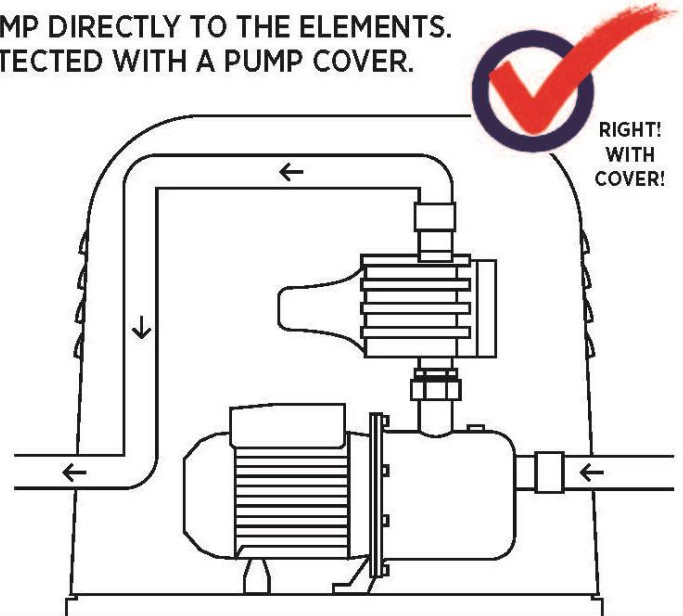
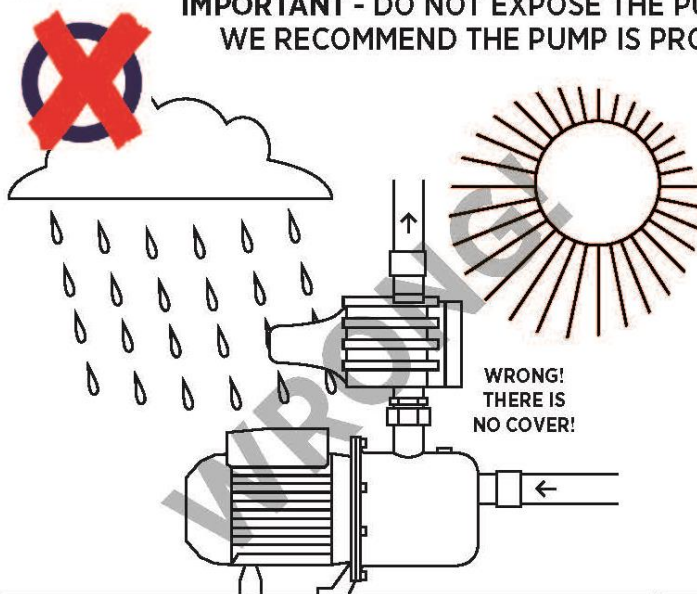

DIAGRAM 14



IMPORTANT! ENSURE THE PUMP IS SIZED CORRECTLY FOR THE JOB. TOO SMALL = LOW PERFORMANCE AND MAY USE EXCESS POWER, AND/OR OVERHEAT THE MOTOR AND/OR CAUSE PREMATURE FAILURE. THIS IS NOT A WARRANTY FAULT IF THIS OCCURS.

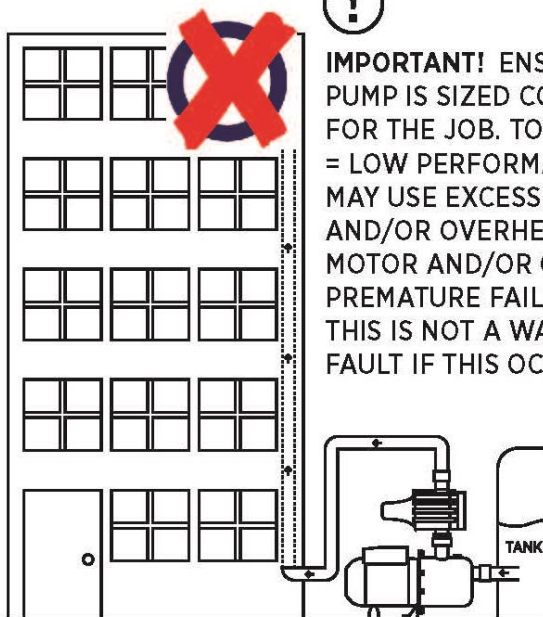
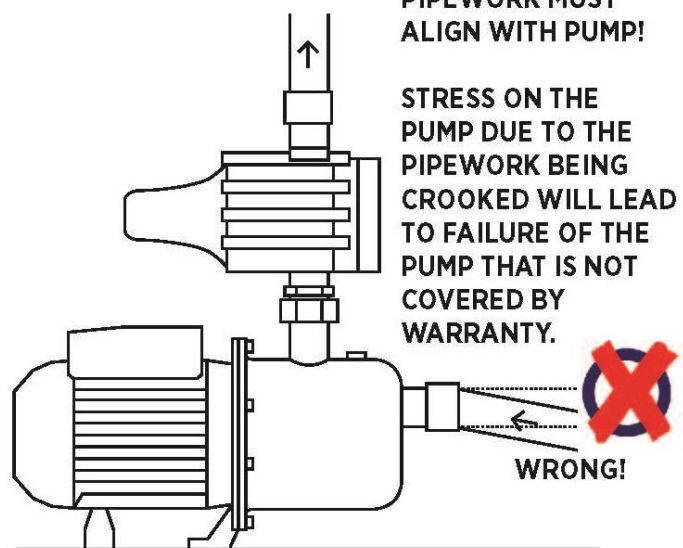

DIAGRAM 15



PIPEWORK MUST ALIGN WITH PUMP!

STRESS ON THE PUMP DUE TO THE PIPEWORK BEING CROOKED WILL LEAD TO FAILURE OF THE PUMP THAT IS NOT COVERED BY WARRANTY.



WARNING: NO RCD/SAFETY SWITCH IN THE POWER CIRCUIT? DO NOT INSTALL PUMPS!!

RainPro RM4000-3 Rainwater & Mains Water Backup System

How the system works;

1. When the Rainwater tank is empty/nearly empty, the pump controller will sense there is insufficient water and turn the pump off.
2. When this happens, the “Failure” or “No Water” light will flash - this does not indicate a fault, it is the normal way the system works.
3. Mains water (Town-Water) will flow freely so you always have water when the Rainwater is “off”.
4. Some pressure difference may be noticed between the different water supplies – this is normal, it is not a fault with the system – the mains water from this system will be at lower pressure than the rainwater pumped by the pump.
5. Occasionally toilet cisterns might make some strange noises due to some air coming through the pipes, this will do no harm, and is a normal part of the automatic operation.
6. The pump will attempt to re-start several times over the period of a few minutes. The pump might “crackle & gurgle” somewhat, due to air in the pump, as it tries to restart, this is not a fault, it is normal.
7. If the pump cannot get enough water it will then stay off for 24 hours, then repeat the same process every 24 hours to check if there is water in the tank.
8. If it happens to do this in the middle of the night it can cause disturbance - in the morning, turn it off, then on again after 30 seconds and it will reset itself so it does the checking in daylight hours.
9. If it is dry for a long time - no rain - it is best to turn the power off to the pump, at the power outlet.
10. All External Pumps MUST be fitted with a Y-Strainer between the pump and the tank, and this needs to be flushed periodically, if it blocks up it is not a warranty problem, it is a maintenance problem.
11. Sometimes even after rain, there might be an air-pocket in the pump and it does not restart. This is NOT a warranty fault!! Simply turn the pump off at the power outlet, and back on after 20 seconds, repeat until water flows normally. If this does not work, you may need to either: [a] Turn the mains off using the MAINS ISOLATION VALVE (see front page) and restart the pump. Or [b] bleed the air out of the pump, refer to the Pump operating instructions.
12. **IMPORTANT – Leak Detection Function:** If the pump is turned on & off more than 7 times in 2 minutes, it will automatically switch itself off completely. **THIS IS NOT A PUMP FAULT!!** Find, isolate and fix the leaking item – toilet cisterns are always the first thing to check – some leak internally into the cistern and DO NOT TRICKLE INTO THE PAN – turn the stop-cock off under the cistern, to check for sure. See also the trouble-shooting section later in this document.
13. Before assuming there is a fault with the pump operation, check the water level in the tank, the pump may not operate unless there is 300 to 700mm of water in the tank, note that tank-level indicators are not always reliable (water level required is dependant on the type of pump & the installation, see also important note below)

IMPORTANT!! FOR EXTERNAL PUMPS: If the OUTLET of the TANK is below the level of the INLET of the PUMP the pump system CANNOT suck the air out of the pipeline, the water level inside the tank will have to be ABOVE the top of the PUMP before the pump will start working again properly.

Installation Instructions and Checklist

- All installations must be in accordance with AS/NZS 3500.1
- Maximum Pressure - A pressure reduction valve must be fitted if mains supply exceeds 500kPa as per AS/NZS 3500.1
- Maximum Temperature – for Coldwater use only.

INSTALLATION GUIDE : TICK AS COMPLETED AND LEAVE THIS FOR THE OWNER

TICK AS

CONDITION OF WARRANTY : this checklist must be completed and left for the owner.

COMPLETED

Step 1 **IMPORTANT: The pump must be LEVEL** or it will malfunction, **mount the pump on a stable and level base**, in an area that is well ventilated and well drained. The pump must be protected from the weather by way of a pump cover or similar structure. Do NOT install external pumps in low areas where water will pool.

IMPORTANT: This external pump Rain-Mains system CANNOT be used for a “Suction Lift” installation, it must have flooded suction AT ALL TIMES, the **water from the tank must gravity-feed into the pump**. The footplate of the pump should be level with, or below, the bottom of the tank. If you need suction lift, you either have to fit a pump shut-off controller with a float switch inside the tank, or use a RM5000 Submersible Pump System.

Step 2 **Connect suction pipe** - with a MINIMUM INTERNAL DIAMETER OF 25mm - from the rainwater tank to the inlet of the pump, the installer MUST include a Ball-valve and a Y-Strainer (or Prefilter) in the suction pipe (the pipe between tank and pump) Leave the ball-valve on the suction pipe closed at this point.

IMPORTANT! Mandatory condition of Warranty:

1) **The suction pipe must be as straight as possible to the pump**, do not have pipes underground as this will lead to air-locks and un-necessary call-outs for the installer. NO WARRANTY if the pipe is less than 25mm INTERNAL DIAMETER.

2) **You MUST install an in-line filter or Y-Strainer *between the tank and the pump*** so any particles cannot clog or cause malfunction of the pump, pump controller, non-return valves, toilet cisterns, washing machines and other fixtures and fittings. NO WARRANTY APPLIES IF NO Y-STRAINER OR PREFILTER IS FITTED.

Step 3 When pipework is completed, **fix the pump into position** using holes provided in base mount of pump.

Step 4 **Prime the pump:** Fill the wet end of the pump with water until the water level reaches the neck of the outlet. Or fill the tank with 300-400mm of water and then open the ball-valve to allow the water into the pump, remove the small priming plug on the pump bowl (wet-end) and allow the air to escape.

Step 5 **Fit the Pump Controller** (Pressure Controller) to the pump and hand tighten brass barrel union (normally it is already assembled) tools or thread seal are not normally required if a Brass Barrel Union is used.

Step 6 **Attach RM4000-3 Valve-set to the pump** as shown in the diagram on page 2, do not over-tighten the hex nut onto the pump or the rubber washer will distort and the connection will leak. Add threadseal tape if necessary.

Step 7 **Connect Discharge pipework to the RM4000-3 Valve-set.** Use WaterMark approved flexible hose, not rigid pipework, to help avoid vibrations from the pump transmitting to the house.

Step 8 **Connect Mains supply to the RM4000-3 valve-set** mains end, ensuring that flow is with the direction indicated on the valves. DO NOT remove or adjust the PRV as it is integral to the function of the system – even if there is a PRV installed on the house supply – all warranty is voided if adjustments are made, and the system will not function correctly.

Important!!! Ensure mains is connected to the correct side, as labelled.

IMPORTANT: if installing close to a wall or other fixture, use barrel-union connections to allow removal if ever required.

IMPORTANT: MAXIMUM PRESSURE - A pressure reduction valve must be fitted if mains supply (Town-Water) exceeds 500kPa

Step 9 If garden use of rainwater is required without using mains water, then this could be taken off between the pump and RM4000-3 valve-set to avoid Town-Water use on the garden – ensure compliance with Government, Local Government and Plumbing Regulations first.

Important!!! Work on the mains supply must be in accordance with the relevant plumbing code.

Step 10 Connect the WaterMark approved Flexi-hose to the house supply-point.

Plug the pump's power lead into the power outlet provided, which must be installed by a licensed Electrician according to Electrical Regulations.

IMPORTANT CONDITION OF WARRANTY:

- Step 11 1) The power outlet used for the **pump MUST BE protected by a RCD** (Safety Switch) – do not install pumps without this protection.
- 2) The Power Outlet **MUST** be in **EASY** reach for the resident – it must **NOT** be up above the rainwater tank where a ladder is required to reach it.
- Step 12 Once all pipe work is connected correctly, **prime the pump** as per the diagram on page 4, **then test the system** by filling the tank with some town-water (if it hasn't rained), then open connected garden taps, flush toilets etc. If the pump fails to operate, re-prime it as per instructions in Step 3. Then **check for leaks** and rectify according to Plumbing regulations. Leaks will cause the pump to cycle, this is not a pump problem.
- Step 13 If you experience any problems, refer to the troubleshooting guide first, before calling for warranty service. A call-out fee will apply for all field service work if it is found not to be a Warranty problem.

INSTALLATION CHECKLIST: MUST BE FILLED IN FOR WARRANTY TO APPLY

Installer Name: Phone Number:
Qualification: (write Owner if applicable)
If installed by a Plumber or Electrician – Licence No:
Installation Address:

Tick the boxes as the item is completed/correct, put n/a if not applicable;

-] The Steps 1 to 12 have been completed
-] The Pump is being used for an appropriate purpose for which it is intended, according to the instructions
-] The Power Circuit the Pump is connected to is RCD (Safety Switch) Protected
-] A Y-Strainer or Pre-filter is installed in the suction pipe to prevent particles entering the pump
-] Barrel Unions are fitted on the pipe connections for easy removal & replacement
-] A Ball Valve or Gate Valve is fitted to the suction pipe (the pipe from tank to pump)
-] Pipe is sized appropriately for the application (diameter and length)
-] The installation is constructed so the pump can be easily removed or replaced.
-] The pump is installed in accordance with National & Local Plumbing Regulations
-] The Electrical Supply cable of the pump is plugged into a Power Outlet that is in accordance with the current standard of Electrical Safety Regulations AS/NZS 3000 – or the pump has been wired directly to the power circuit by a Licenced Electrician, with an isolation switch incorporated.
-] The Pump has been primed (filled with water) started, tested, and operates correctly.
-] The pipes and connections and the barrel-union on the pump, and toilet cisterns (if connected) have been checked for leaks.
-] The pump is protected from sunlight & rain, with a suitable vented pump-cover or enclosure.
-] The Owner has been shown how to re-prime and re-set the pump (re-fill the pump with water if it runs dry) (if owner/resident not in attendance this is not applicable, ensure this instruction manual is left for the owner.)

THINGS TO CHECK BEFORE YOU CALL FOR SERVICE

Trouble Shooting Guide

TROUBLE-SHOOTING CHECKS FOR PUMP ISSUES - Check the following before requesting service or repair. A call out fee applies to all field services outside of Warranty Period and additional labour cost may apply.

Tick box after check has been completed

WARNING!!!! SAFETY FIRST – TAKE PRECAUTIONS!!!! Before servicing a pump, always shut off the power supply and then make sure you are not standing in water and that there is no risk of electrical shock.

If the pump is direct-wired to the electrical circuit, contact a licensed electrician to disconnect it.

1. PUMP CONTINUES TO START WHEN WATER TANK IS EMPTY

1.This is either due to an airlock somewhere in the pipe or the pump, or it is the normal re-start function of the pump, or some debris inside the pump controller, simply turn the pump off at the power outlet until rain re-fills the tank. Note that you will likely need to reprime the pump when the tank fills again, refer to the diagram on page 4, for guidance on priming the pump.

2. PUMP NOT OPERATING

1. Has the Circuit-breaker or Safety Switch tripped off? If so, in a safe manner (**SAFETY FIRST:** do not touch the pump or water) check that it is the pump (not something else) and if you are certain it is the pump that is causing the problem, log a ticket if it is in warranty period, at www.reefe.com.au/warranty/ If out of warranty search the internet for “pump repairs in my area”

2. Is there rainwater in the rain water tank? NOTE: tank level indicators are not always accurate!! Check inside the tank to be sure of the water level.

To be sure there is rainwater in the tank > tap the side of the tank, does it sound hollow? Feel the side of the tank, you can normally feel a temperature difference from where the water is to where there is none. If you cannot tell that way, get a torch and look in through the tank opening. The pump generally needs 300-400mm of water to work properly. Be sure, if you call for service and tank is found to be empty, you will be liable for the cost of the service call.

3. Pump has an air-lock >Start and stop several times by turning the power off, wait 30 seconds, and turn on again, repeat if necessary. NOTE: you might need to turn the Townwater supply OFF to make it easier to re-start the pump.

4. Are all pipe work valves open between tank to pump?

5. Is the pump plugged in correctly and switched on at the wall? Does the plug look wet? Isolate power at main switch, remove plug and allow to dry. Also check power connection between pump and the pump controller is intact/pushed hard together. If the problem continues, contact a licensed electrician.

6. Does the Rainwater have gravity feed (flooded suction) to the pump? If not, the pump will not work.

7. Check the status of the Pump Controller – if the FAILURE/LOW WATER light is on, it has detected no water – recheck the tank has water in it, most pumps will require minimum of 300mm of water level to operate. Then re-prime it as per below and press re-set.

NOTE: Tank level indicators are not always accurate – look inside the tank to be sure.

8. If all of the above are checked and pump is still not pumping you may need to re-prime the pump. Refer to the diagram on page 4, or read on: This can be done by loosening the nut on top of the stainless steel wet end above the inlet on pump. Once you have loosened this nut, air should come out followed by water. Tighten nut as soon as water appears. (If the TANK is EMPTY, or is BELOW the pump, this will not work, simply turn the pump off until it rains again). Once nut is done up tight, press the reset button on the pressure controller and hold it for a few seconds until pump runs on its own. The pump will run until all the pipe work has been pressurized then automatically switch off. The pump will start again once line pressure drops, which occurs when a tap is turned on.

NOTE: you might need to turn the Townwater supply OFF to make it easier to re-prime the pump.

9. For pumps drawing from an underground tank, or tank at a lower level – you CANNOT use the RM4000-3 with an External Pump, use Submersible RM5000-3 Pump System (or you will have to install a PUMP SHUT-OFF CONTROLLER).

3. Pump does not run or motor runs for a short time, then stops

1. Circuit breaker or Safety Switch is off or fuse has blown > in a SAFE manner investigate why this has occurred, by process of elimination > do not assume it is the pump > if you cannot do this safely, have a licenced Electrician check and rectify it.

2. Water level in the tank is too low > Top up or use alternative supply > turn pump off until the tank fills

3. Electrical components have been flooded > It is likely that the pump will need to be replaced > in a SAFE manner investigate why this has occurred, by process of elimination > do not assume it is the pump > if you cannot do this safely, have a licenced Electrician check and rectify it.

4. Pump plug is not connected properly, or has been flooded or wet > also check the connection between the pump and the controller to ensure it is pushed together properly > if they are OK then isolate the power at the main switch, remove plug & allow to dry. If the problem continues, contact a licenced electrician to check the cause.

5. If all of the above are OK, the pump might have overheated and triggered the thermal overload switch > Turn it off and wait 30 minutes for it to cool down and turn it on again > If the pump does not operate normally, investigate why, it might be blocked with debris, or the Y-Strainer/Prefilter might be blocked > flush clean and re-assemble.

4. Pump runs but does not deliver water or only a small amount of water

1. Check valve is installed backwards, arrow on valve should point in direction of flow > have the installer fix this.

2. Discharge shut-off valve/ball-valve / gate-valve may be closed > open the valve.

3. Impeller or volute openings are fully or partially clogged or it might be blocked with debris, or the Y-Strainer/Prefilter might be blocked > flush clean and re-assemble > if it is the pump, disconnect from the power supply, and if you are competent to do so, disassemble the pump and clean. If not, have a pump technician do it for you.

4. Pump is air-locked > Start and stop several times by turning it on and off with 20 seconds between. If this does not work, see 2.9.

5. Vertical pumping distance is too high > Reduce distance or upgrade to a larger pump.
6. Foot valve blocked > Clean or replace the FOOT valve
7. Tank too low water level > Check the suction and water levels

5. Pump runs and does not stop or runs when no taps are in use

1. In most cases this situation it is due to a leak in pipework or leaking toilet cisterns or underground pipe leak (wet soil, muddy, grass growing well!) > it is not a pump fault > ascertain by process of elimination what is leaking > the quickest way to ascertain if it is in the house is usually by checking the water meter, follow this process;

a) Turn the pump off

b) Then ensure all water outlets in the house and garden etc are turned off, ensure that any garden taps are off and not dripping.

c) Check the water meter, is it turning at all? It may be very slow, so leave everything off, and re-check in an hour

d) If there is movement in the water meter this would indicate a leak somewhere in the piping, or toilet cisterns, sometimes the toilet cisterns leak very slowly on the inside, but it can be enough to make the pump start & stop

e) Most toilets have a stop-cock under the cistern, so you can easily turn them off, and repeat the test, to see if it is the cistern that is at fault (the only sure way to check toilet cisterns is to turn them off at the stopcock which is usually under the cistern as most of them will not run into the pan – the leak can be the inlet valve inside the cistern)

f) If you perform all of the above and no leaks are evident in the plumbing system, it might be a fault with the pump, this is how to test that;

g) turn off the isolation valve on the discharge pipework > does the pump stop = the leak is further down the pipe-line

h) If you have proved there is no leaks in the house, it could be some grit or particle is caught in the check-valve of the Pump – open all taps fully open and flush all toilets to try and flush the particles out, test again after doing this.

2. There could be debris inside the Pump Controller > open all taps fully to try and flush it out > if this does not work disconnect from the power supply and [a] remove the pipework off the top of the controller there is probably some debris in the brass “popit valve” that is in the top of the controller, carefully remove the debris > if it is not that disassemble the pump controller and clean, or have a pump technician do it for you.

6. Pump not pumping properly

1. Too high head or pump under specified > Check specifications.

2. Too low water level > Check the water level in the tank, tank level indicators are not always accurate

3. Loss of prime > Check foot valve (if fitted), re-prime the pump.

4. Leakage of inlet pipe > Check the inlet pipe is not taking in air, check all joints.

5. Inlet Pipe has rise and fall (Dips) or has too many elbows or is blocked > Fix suction pipe so it is both perfectly straight and level, OR rises all the way to the pump, or turn the pump off and wait for the tank to fill more > NOTE: if the inlet pipe is not straight to the pump it is most likely that you WILL get airlocks in the pipework especially when the tank has low water, this is NOT a pump fault > turn the pump off until the tank fills to have 500mm depth or more.

6. If a check valve has been installed directly on the discharge of the pump controller, this may cause the pump controller to malfunction > Move the check valve to a different position.

7. Safety Switch (RCD) or Circuit Breaker trips when the pump starts

1. WARNING!!! If the Safety Switch has tripped do not touch the Pump or surrounding pipework. With the Safety Switch still off, remove the plug of the pump from the power outlet and try another small appliance such as a fan or electric drill, to check the power outlet is OK. If it trips the power again, it would indicate the issue is with something else, find this by process of elimination, or call a licenced electrician. If you prove that it is the pump, do not plug it back in, have it replaced immediately. If it is in warranty log a warranty claim here: www.reefe.com.au/warranty/ or mail us at PO BOX 650 MORNINGSIDE QLD 4170 or send an email to csv@ascento.com.au with copy of your purchase receipt, description of the problem, and your name and address and phone number.

2. Circuit is overloaded with too many appliances connected to it > contact a licenced electrician to install additional circuit

3. Power plug is wet > refer 3.3 & 3.4.

4. Pump has been flooded > refer 3.3

5. Pump impeller is partially clogged with particles, causing motor to run slow and overload. Disassemble pump and clean.

6. Motor stator may be overheating. Ensure there is good ventilation for the motor, have checked by a licensed electrician.

7. If none of the above, the Motor may be defective > have it checked by a qualified technician

9. MAINS WATER DOES NOT FLOW WHEN POWER IS OFF TO PUMP

1. This is very unlikely due to the design of the RM4000-3 system, the possible cause for this problem would be a blockage in one of the valves, which is not a warranty problem > have the valves disassembled and cleaned by a licensed Plumber, or replaced.

10. MAINS WATER FLOWS VERY SLOWLY WHEN POWER IS OFF TO PUMP

1. The Town-water supply is usually less pressure than the pump supply. This is normal, it is not a fault. If the Town-water supply is very slow (a “dribble”) the possible cause for this would be a partial blockage in one of the valves, which is not a warranty problem > have the valves disassembled and cleaned by a licensed Plumber.

2. Filter between pump and house (if fitted) is blocked - change the filter cartridge.

3. Inlet filters on the inlet of the Toilet Cisterns and Washing Machine are blocked - turn the pump and the mains water off, disconnect the hoses and clean the filters.

11. I have done all above, what do I do now?

If you have followed all the above instructions and continue to have a problem with your RM4000 / RM5000 / RC550 system & if you are sure the problem is a warranty problem please contact Ascento: Ph: 1800 807 604 or email: csv@ascento.com.au

We will need your proof-of-purchase and your name, phone number and address. It also is of great assistance if you can take a couple of photos of the system and email these to us with your details. Note that field-service staff can usually only access in the hours 9:00am to 3:30pm weekdays excluding public holidays. Please be aware that if our field service agent attends and finds it is not a warranty problem the applicable charges must be paid by you, at the time of the visit.

For pumps out of warranty please contact a local pump specialist – search internet for “Pump Repairs in my area”

Installation issues are covered by the Builders/installers warranty policy.

OPERATING AND MAINTENANCE INSTRUCTIONS

- OPERATING:** - No further action is needed once the system is installed; it will operate automatically
- MAINTENANCE:** start by doing this MONTHLY: for external pumps – flush the Y-Strainer by opening the bung. Ensure you re-fit the mesh strainer after doing this. If you find no debris, do it 2 monthly, review and repeat according to the conditions of your tank (installations where there is a lot of trees will need the Y-Strainer flushed frequently)
- No other periodic maintenance is usually necessary, except if low flow rate is found when the MAINS supply is in use, ask a licensed Plumber to disassemble and clean blockages from the RM4000-3 valve assembly. This is not a warranty fault it is a maintenance item. NOTICE TO PLUMBER: avoid adjusting any of the Valves as they are factory set and must not be interfered with.
- TROUBLESHOOTING:** - Refer to the Troubleshooting Guide.
- SPARE PARTS LIST IF REQUIRED:** -

RainPro™ RM4000-3 Water Controller - Spare Parts		
Order Code	Description	Price inc GST*
RMV3550	RainPro RM4000-3 Valve Assembly	POA
8379	RainPro RM4000 Pressure Controller *external pumps only*	POA
Pump	As per the model supplied	POA

- AFTER SALES SERVICE:** - Not normally necessary, however if you have any queries please call 1800 807 604
- RECOMMENDED PRESSURES:** - A pressure reduction valve must be fitted if mains supply exceeds 500kPa

OWNERS RECORD - FILL IN AND RETAIN THIS WITH YOUR ORIGINAL PURCHASE RECEIPT

PURCHASER NAME..... PHONE NO.....
 DATE OF PURCHASE/...../..... DEALER/STORE NAME.....
 DEALER SUBURB/TOWN..... PHONE NO.....
 BRAND & MODEL NUMBER OF PUMP..... SERIAL/BATCH NUMBER.....
 (Serial/Batch Number for External Pumps only – this is on the nameplate on top of the Electric Motor)
 Do NOT send this form to us, retain it for your record.

Rain to Mains Systems 2 Year WARRANTY CONDITIONS

- Our goods come with guarantees that cannot be excluded under the Australian Consumer Law. If you are a consumer as defined by the Australian Consumer Law, you are entitled to a replacement or refund for a major failure and for compensation for any other reasonably foreseeable loss or damage. You are also entitled to have the goods repaired or replaced if the goods fail to be of acceptable quality and the failure does not amount to a major failure. The following conditions form part of the instructions and do not over-ride your statutory rights.
- This warranty against defects covers failure due to manufacturing defects within the period as stated in the table below from the date of original purchase, for SUBMERSIBLE or EXTERNAL CONSTANT PRESSURE PUMPS and RAIN-TO-MAINS SYSTEMS, supplied by ASCENTO GROUP AUSTRALIA that are purchased and used in mainland Australia. In the case of a failure caused by a defect in the product, within the specified period from the date of original purchase, you can return it to the place of purchase for a refund or you can request for us to arrange for the pump to be repaired.
- Faults or losses or failure caused due to but not restricted to any of the following: improper use, improper installation, foreign objects inside the pump or pump controller, normal wear and tear, accidents, misuse, lack of maintenance, not following the installation instructions, damage caused by lightning strike, or power surges, or power spikes or power brownouts, or operating the pump on power other than correct mains power, or operating the pump on power supplied by a

domestic generator, power supply of voltage less than 230V, power supply of voltage above 240V - are not covered by warranty. Improper use is defined by us, at our sole discretion.

4. The complete Impeller set (including shaft), Seals and O-rings are all wearing items and therefore are not covered for "normal wear and tear". They are covered by this warranty if they fail due to a manufacturing defect. The Warranty also excludes accidental or deliberate breakages, fading or breakdown due to the effect of exposure to sunlight or chemicals or any other external factor that may affect the life of the product.

5. Warranty will be void if any tampering or removal of identification labels or electrical cables has occurred, or any non-genuine parts have been fitted, or repairs have been carried out by unqualified persons. No warranty applies for goods sold or used for HIRE or RENT or LEASE. No warranty applies, and no liability is accepted, if the pump is used in circumstances that we define as: HAZARDOUS SITUATIONS, MINE SITE, REMOTE AREA, INDUSTRIAL APPLICATION, or any other UNSUITABLE APPLICATION, all of these circumstances are defined by us at our sole discretion.

6. This product is guaranteed as fit for the purpose of pumping CLEAN FRESH WATER for normal domestic household use, and for NO OTHER USE. Performance data quoted is generally from test data and is approximate and does not take into account factors in the installation such as loss of pressure and flow due to pipework & pipe-fittings & valves. It is the purchaser's responsibility to ensure that the product is fit for their purpose and of sufficient size & performance for their application.

7. IMPORTANT: No electrical appliances last forever. Therefore, ALL installations of these pumps and valve-sets supplied by us, must be constructed to allow the owner to easily remove them for servicing, and to easily remove them for replacement, warranty replacement or upgrading. The installation must NOT be constructed in such a manner that specialized tools, or paid tradespersons, or external paid contractors, are required to be engaged in order to remove and/or replace and/or refit the pump, therefore all pumps must be installed using barrel-union connections to facilitate easy servicing or replacement. If the rainwater tank is installed under eaves or other structure such as a deck, ensure that the pump can be easily removed for servicing or repairs. Warranty replacement does not normally include costs of removal and re-installation as we have no control over the method of installation.

8. Before installing or servicing disconnect from the power supply. A ball-valve or gate-valve must be fitted on the suction, and the Town-water backup supply where fitted. A "First-flush-diverter" or similar device must be installed to prevent debris from entering the tank, or a filter screen through which all the incoming water passes before entering the tank. A Y-Strainer or Pre-filter must be installed: (a) For external pumps on the suction (inlet) pipe and (b) For submersible pumps on the discharge before the pump controller (for where there is an external pump controller) - to prevent particles entering the pump and fixtures and fittings including non-return valves. This instruction is a condition of warranty; all warranty is void if this instruction is not followed.

9. This pump is not to be used as your sole water supply. For critical applications where loss of water supply could cause serious consequences, use a DUAL PUMP System so you have a backup water supply or use a TOWN-WATER BACK-UP System.

10. This pump MUST NOT be installed in any manner that if it were to leak or fail to work that it would cause damage or loss to property or persons. It MUST be installed in a well-ventilated and drained area. All warranty is void if this condition is not heeded and no liability can be accepted in the case of damage or loss caused by failing to comply with this condition.

11. The Pump must be connected to a suitable circuit with an integral RCD (safety switch) in the circuit breaker. All warranty is void if this instruction is not followed.

12. RIGHT TO INSPECT: We reserve the right to inspect the product and installation, prior to accepting any warranty claim. We may inspect by use of drone technology, with property owners permission. We also reserve the right to request and require photographs or video evidence in lieu of physical inspection, at our sole discretion. Refusal of inspection cancels all warranty and liability.

13. This warranty does not exclude any non-excludable rights according to Australian Law. However any condition that is made void by Australian Law does not void the remaining conditions, which shall stand unaltered.

14. In the case of a fault, refer to the Trouble Shooting Guide first. If these steps do not rectify the problem, and the fault is due to a manufacturing defect or product failure not caused by improper installation, improper use or lack of maintenance, return the faulty appliance to the original place of purchase with proof of purchase for replacement or refund. Alternatively you can mail us at PO BOX 650 MORNINGSIDE QLD 4170 or send an email to csv@ascento.com.au with copy of your purchase receipt, a description of the problem, and your name and address and phone number - we will review your request and send you a replacement directly if we accept your warranty claim. Or call us on 1800 807 604 with the above information; however we will always require a copy of your purchase receipt. If an exact replacement is not available, the closest equivalent product will be supplied at our discretion. Do not send the product to us unless we ask you to do so.

WARNING!!!! SAFETY FIRST – TAKE PRECAUTIONS!!!

* Before servicing a pump, always shut off the power supply and then make sure you are not standing in water and that there is no risk of electrical shock.

* If the pump is direct-wired to the electrical circuit, contact your qualified licensed electrician to disconnect if required.

DO NOT INSTALL PUMPS ON A PREMISES WITHOUT RCD (SAFETY SWITCH) PROTECTION.

DO NOT ATTEMPT ELECTRICAL REPAIRS OF ANY SORT UNLESS YOU ARE AN AUSTRALIAN-LICENSED ELECTRICIAN

*** IMPORTANT NOTICE TO OWNER AND INSTALLER – SERVICER: *Any replacement parts including the Backup Valves, Pump Controller and the Pump, MUST BE REPLACED WITH GENUINE PARTS or the system will malfunction.***

Manufactured by ASCENTO GROUP AUSTRALIA 37 Export St, Lytton, Brisbane, QLD 4178

P: 1800 807 604 E: sales@ascento.com.au