

TYPICAL SINGLE PUMP STATION

WITH HIGH LEVEL ALARM

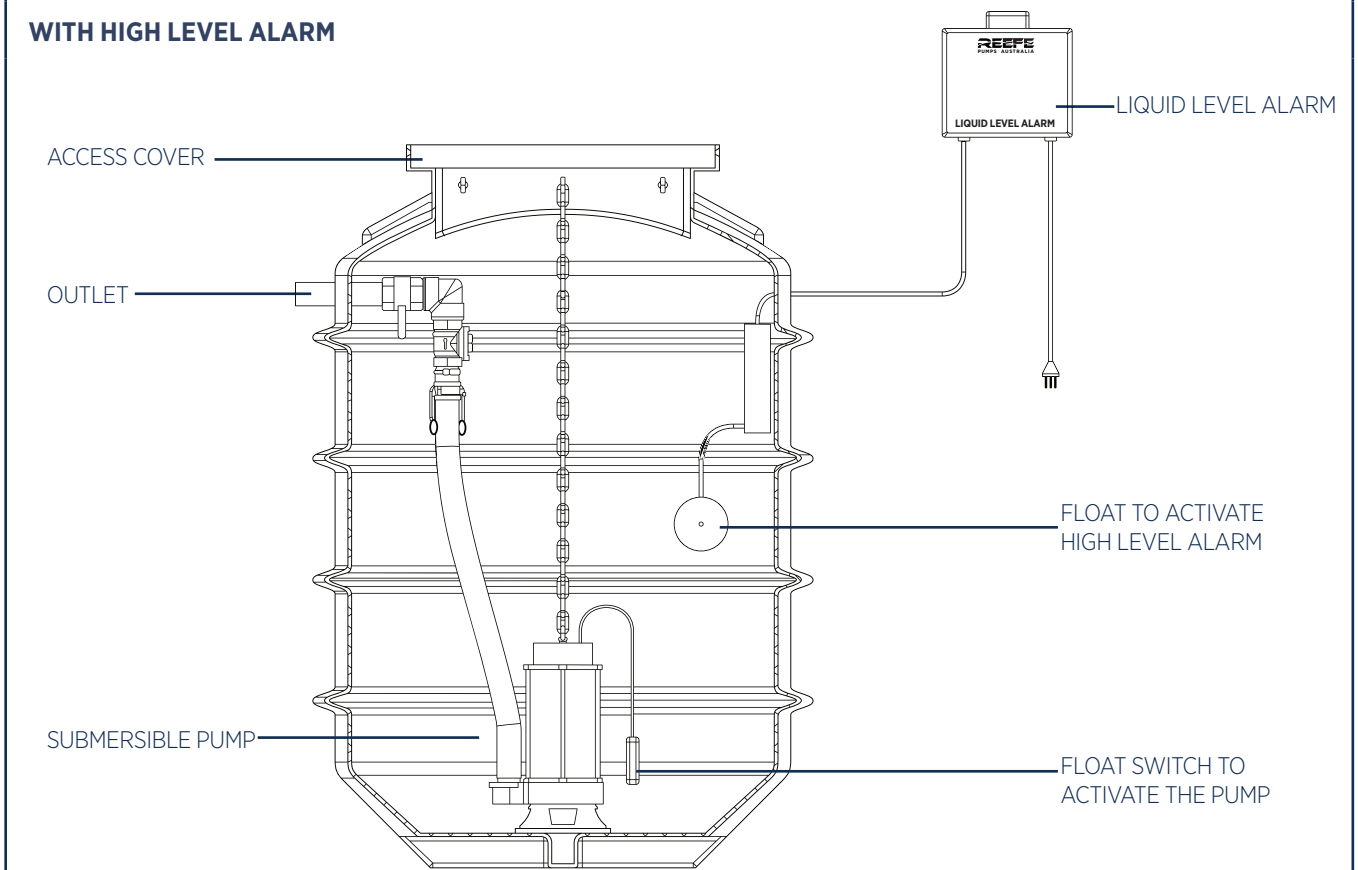

TYPICAL DUAL PUMP STATION

WITH DUAL PUMP CONTROLLER

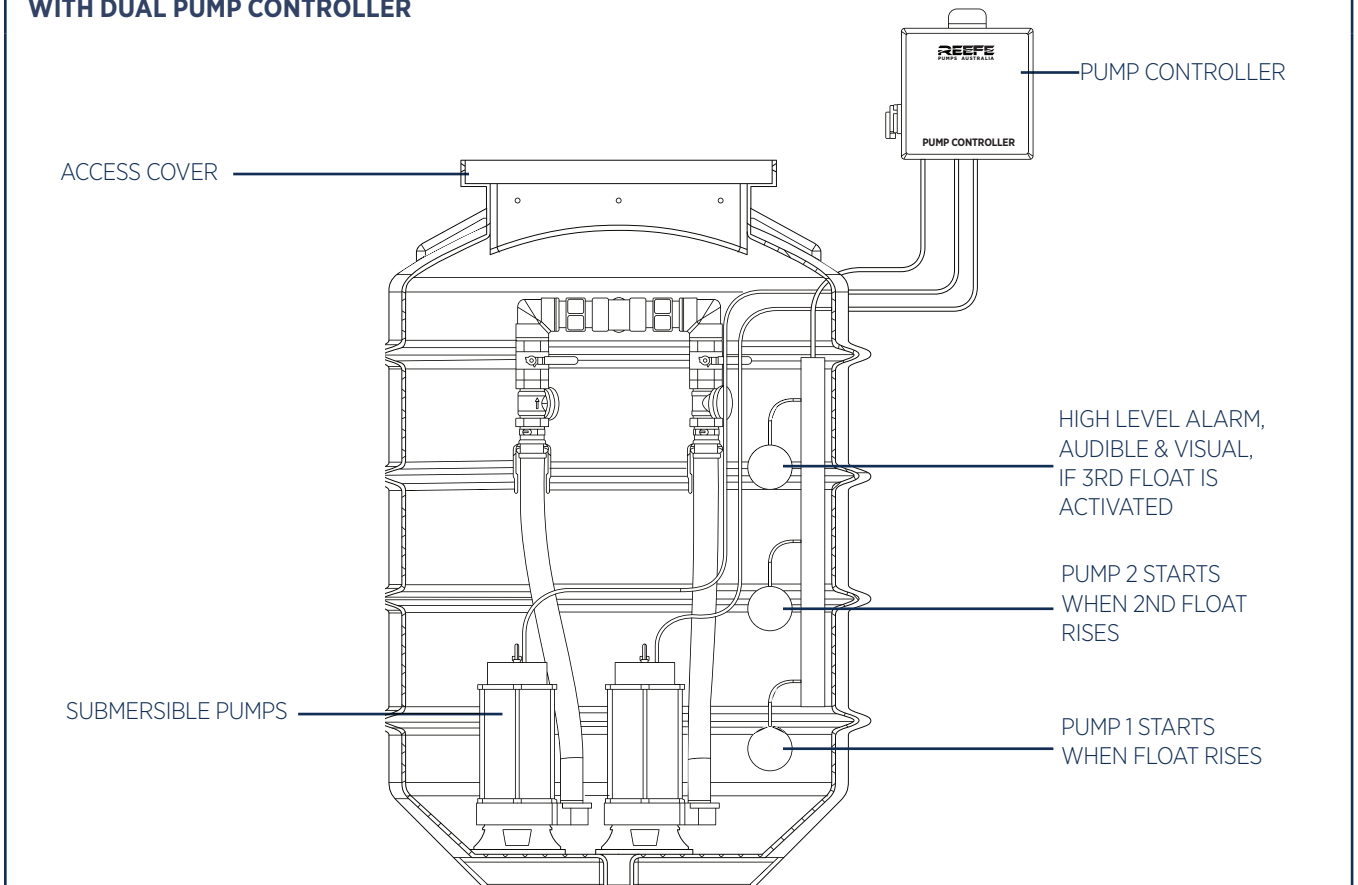

POLY PUMP WELLS

Polyethylene pump wells are strong, lightweight and UV resistant rotomoulded tanks.

All tanks are engineered to Australian standard AS 1546, approved by NSW Health, and covered by a 5 year warranty.

250L POLY PUMP WELL 22 KG	700L POLY PUMP WELL 36 KG	1200L POLY PUMP WELL 70 KG	1600L POLY PUMP WELL 130 KG
Code: 13144 Access Opening: 600x600	Code: 13168 Access Opening: 600x600	Code: 13175 Access Opening: 600x600	Code: 25857 Access Opening: 600x600

NOTE: The Pump Wells and the Access Covers are sold separately. Please advise which type of Access Cover is required.

POLY PUMP WELLS

Polyethylene pump wells are strong, lightweight and UV resistant rotomoulded tanks. All tanks are engineered to Australian standard AS 1546, approved by NSW Health, and covered by a 5 year warranty.

<p>2000L POLY PUMP WELL 190 KG</p>	<p>3000L POLY PUMP WELL 245 KG</p>	<p>5000L POLY PUMP WELL 370 KG</p>	<p>DOWNLOAD OPERATIONS MANUAL</p>
<p>Code: 25864 Access Opening: 600x600</p>	<p>Code: 25338 Access Opening: 600x900</p>	<p>Code: 13205 Access Opening: 600x900</p>	
			
<p>QUOTE REQUEST FORM</p>			
<p>NOTE: The Pump Wells and the Access Covers are sold separately. Please advise which type of Access Cover is required.</p>			

ACCESS COVERS & GRATES

Access covers and grates are designated by classes A, B, C, D, E, F and G according to load capacity as set out in the table below. The design loads as specified below, may be used as a guide it is critical that you consult a qualified engineer or designer to ensure the correct class is chosen. The appropriate class for a cover or grate depends upon the place of installation. Some places of installation, relative to class, are outlined below. The selection of the appropriate class is the responsibility of the designer and where there is doubt the stronger class shall be selected.

Load Classifications of Covers and Grates AS3996:2006 – Access Covers, Road Grates & Frames

RATING	CLASS A	CLASS B	CLASS C	CLASS D	CLASS E	CLASS F	CLASS G
Typical Use	Areas (including footways) accessible only to pedestrians and pedal cyclists, and closed to other traffic (extra light duty)	Areas (including footways and light tractor paths) accessible to vehicles (excluding commercial vehicles) or livestock (light duty)	Malls and areas open to slow moving commercial vehicles (medium duty)	Carriageways of roads and areas open to commercial vehicles (heavy duty)	General docks and aircraft pavements (extra heavy duty - E)	Docks and aircraft pavements subject to high wheel loads (extra heavy duty - F)	Docks and aircraft pavements subject to very high wheel loads (extra heavy duty - G)
Nominal Wheel Loading (kg)	330	2,670	5,000	8,000	13,700	20,000	30,000
Serviceability Design Load (kN)	6.7	53	100	140	267	400	600
Ultimate Limit State Design Load (kN)	10	80	150	210	400	600	900



CLASS A POLY COVER



CLASS B COMPOSITE COVER

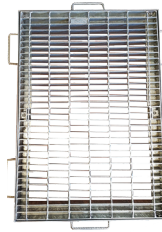

CLASS B GRATE & FRAME



CLASS D COVER

CODE	DESCRIPTION	CLASS	MATERIAL	TYPE	NOMINAL SIZE
13151	Class A Poly Cover	A	Poly	Cover	600 x 600mm
17036	Class B Composite Cover & Frame	B	Composite	Cover	600 x 600mm
26861	Class D Cast Iron Access Cover & Frame	D	Cast Iron	Cover	600 x 600mm
25376	Class B Composite Cover & Frame	B	Composite	Cover	600 x 900mm
26878	Class D Cast Iron Access Cover & Frame	D	Cast Iron	Cover	600 x 900mm
25352	Class A Galvanised Grate & Frame	A	Galvanised	Grate	600 x 600mm
25369	Class B Galvanised Grate & Frame	B	Galvanised	Grate	600 x 600mm
25604	Class B Galvanised Grate & Frame	B	Galvanised	Grate	600 x 900mm
25383	Class D Galvanised Grate & Frame	D	Galvanised	Grate	600 x 900mm

NOTES:

- Nominal wheel loads are given for guidance only. Consideration should be given to the type, size and pneumatic pressure of the load applied.
- Class B design loads exceed AS 5100.2 requirements for footway loading.
- Class D design loads exceed AS 5100.2 requirements for a W80 wheel load.
- Class C units are based on intermediate load.
- The serviceability load is set at 2/3 of the ultimate limit state design load.
- A force of 1 kN approximately equal to the weight of 100kg.

Other options available on request including:

Concrete mill covers, multipart covers, paver infill covers, tile infill covers, stainless steel or brass edged covers, round covers, gas light covers, bolt down covers