

PUMP CONTROL OWNER'S OPERATION MANUAL

Hot Water Recirculator Installation
and Operating Instructions

MODEL: RAM-30004-TC c/w Time Clock

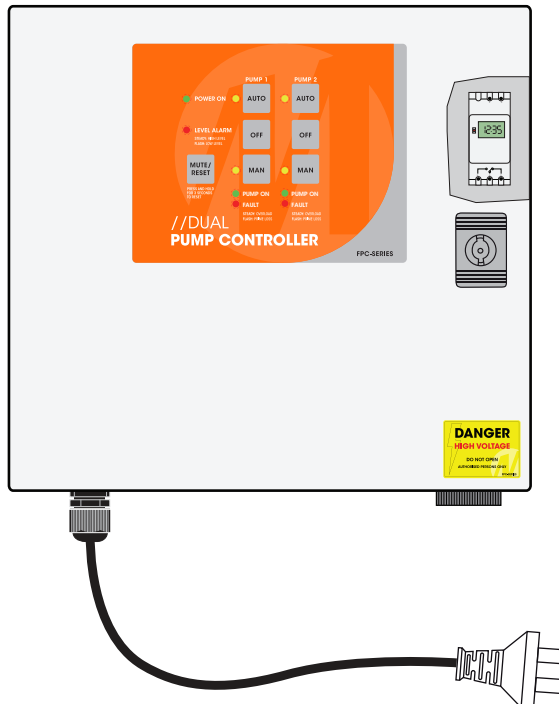

INSTALLATION

MOUNTING

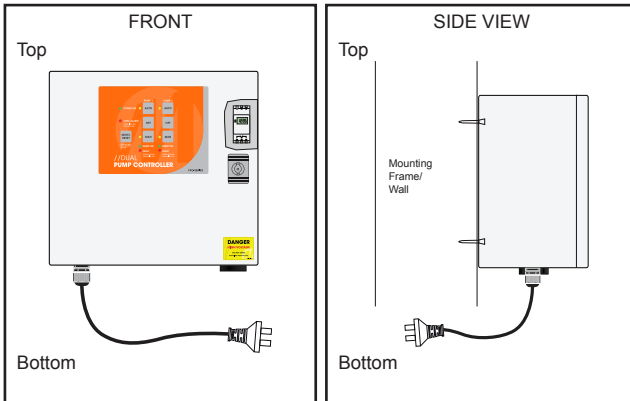

1. Controller enclosure must be mounted in a vertical position.
2. Ensure mounting method does not compromise enclosure weather proof rating.
3. Ensure cables/conduits entering the panel have mechanical protection and that the penetrations are sealed and do not compromise the weather proof rating of the enclosure.

CONNECTION

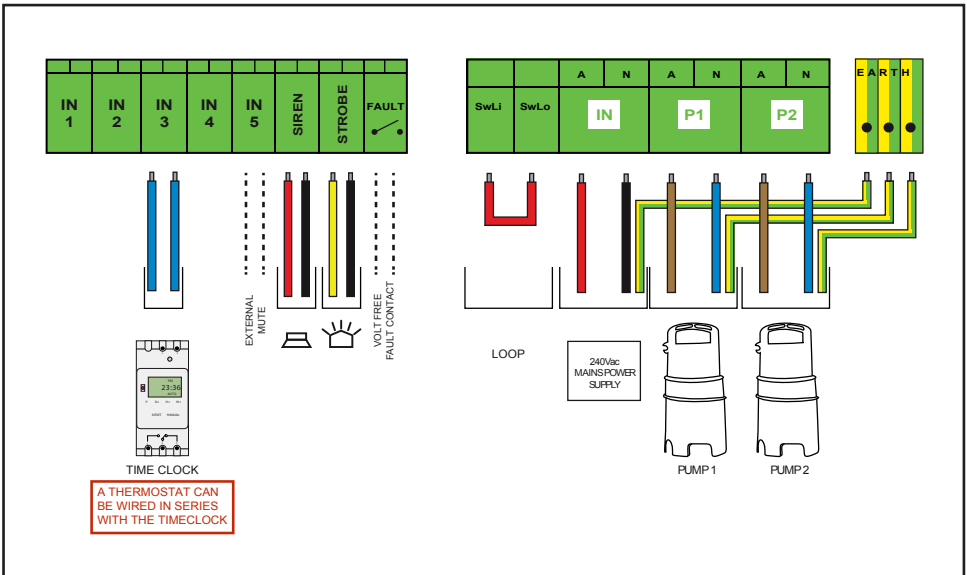

Note: Controller must be earthed and all electrical connections must be carried out by a suitably qualified Electrician.

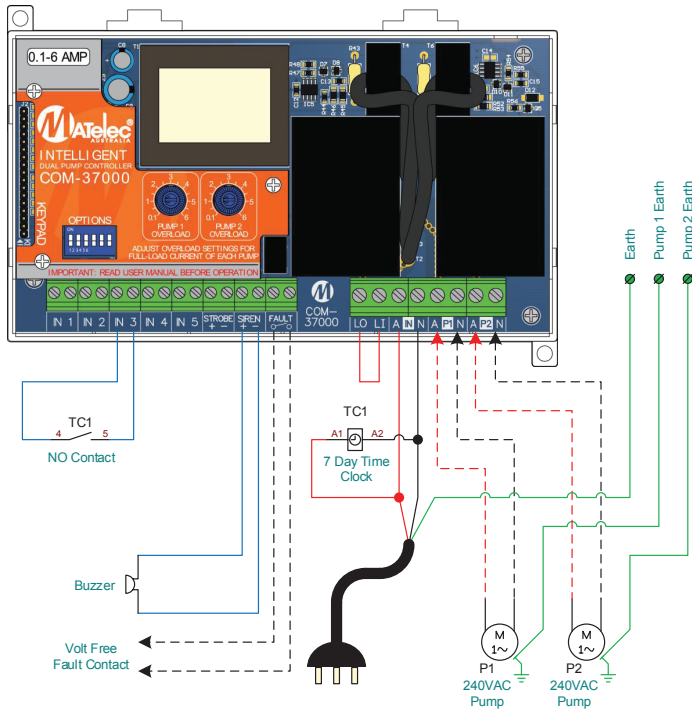

FEATURES

The RAM-30004-TC is an off the shelf, ready to go hot water recirculator available in two ranges, 0.1-6amp and 5-16amp. Its design allows for direct connection of pumps, and an option for connecting a thermostat into input 3 if required

The following features are included in the RAM-30004-TC:

- 2x 230Vac Pump outputs. Using a heavy duty relay capable of switching pumps up to 1.5kW.
- Current monitoring of pumps for detection of overload and subsequent shutoff.
- 2x 12Vdc outputs for siren (included as standard), and strobe (not included as standard).

These are protected from overload by a current sensing circuit.

- 1x Voltage free normally open 'common fault' output (rated to 24VDC, 1A).
- 1x Dual Pump Keypad Interface
- 1x External mute button input (IN5 input screw terminals).
- DIP switch 3 'ON' for 6 hour alternation
- 7 Day Time Clock allowing for programmable ON / OFF times

AT A GLANCE

A quick reference to the controller's Keypad and Indicator functions and meanings.

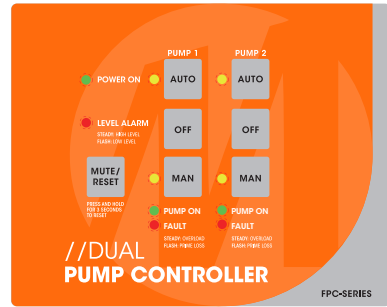



KEYPAD

INDICATORS

- 
POWER ON
POWER ON
 Power is turned on.

- 
LEVEL ALARM
LEVEL ALARM ON
 Not used

- 
PUMP ON
ON STEADY
 Pump switched on to run.

- 
FAULT
ON STEADY
 A pump fault/overload has occurred.

PUSH BUTTONS

- 
MUTE/RESET
 Silences the siren and if held down for 3 seconds, clears all faults

- 
AUTO
 If selected (the LED indicator will confirm if on) the particular pump is set to Automatic Pumping Mode

- 
OFF
 Turns pump off

- 
MAN
 If selected (the LED indicator will confirm if on) the pump is set to Manual Pumping Mode

DISTRIBUTED BY:

INSTALLATION DATE:

SERIAL NUMBER:

ASCENTO Group Australia reserves the right to alter technical specifications without notice.