



PUMPS AUSTRALIA

BETTER • FASTER • EASIER



INDUSTRIAL CUTTER PUMP

EXPLODED VIEW &
INSTRUCTION MANUAL

MODEL: RCE160
CODE: 22863

PARTS LIST & EXPLODED VIEW

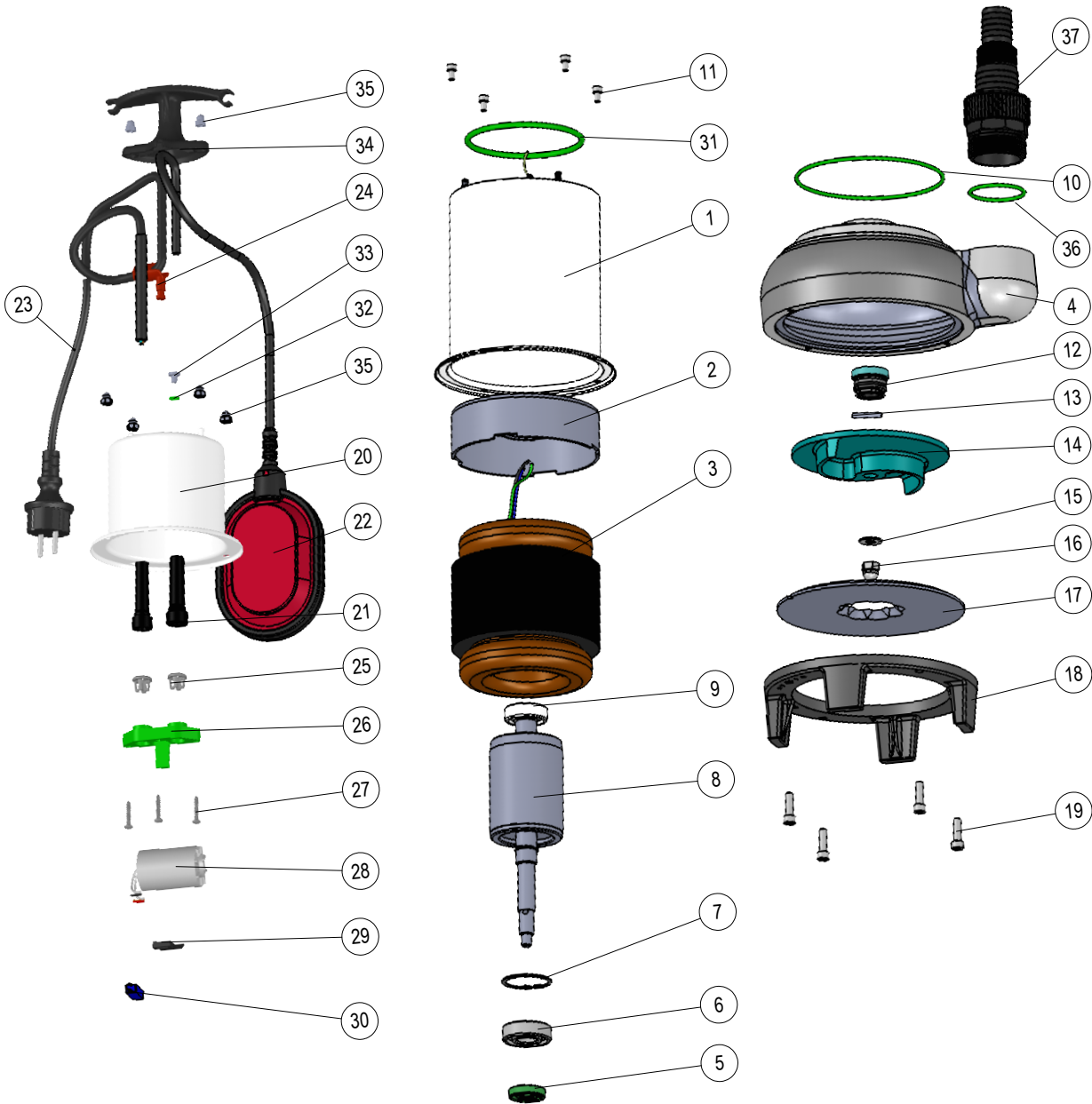

CUTTER PUMP RCE160

Refer next page for Componentry Listing

COMPONENTS & MATERIALS

POSITION	COMPONENT	POSITION	COMPONENT
1	Electric Motor Body	20	Inox cover
2	Bearing Brush	21	Cable Gland
3	Coil	22	Float Switch
4	Pump Case	23	Power Cord
5	Simmering	24	Cord Clamp
6	Bearing	25	Cable Gland Collar
7	Seeger Ring	26	Cable Gland Collar
8	Rotor	27	Screw
9	Bearing	28	Capacitor
10	O Ring	29	O Ring
11	Screw	30	Current Protection Relay
12	Mechanical Seal	31	O Ring
13	Pin	32	O Ring
14	Impeller	33	Screw
15	Washer	34	Handle
16	Nut	35	Nut & Washer
17	Cutting Disc	36	O Ring
18	Leg	37	Connection Plug
19	Screw		

CUTTER PUMP RCE160

POSITION	COMPONENT	MATERIAL
1	Motor Body	INOX Stainless Steel
2	Hose Tail	Noryl PPO
3	Axial Seal	Ceramic Silicon
4	Pump Case	INOX Stainless Steel

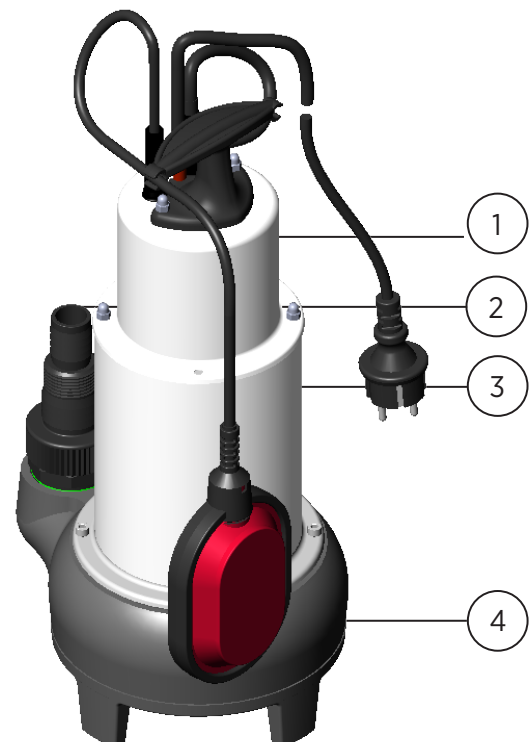

WARRANTY | INSTRUCTION MANUAL

CUTTER | GRINDER | DRAINAGE PUMPS

PRIOR TO INSTALLATION & OPERATION

The installer must consult a WHS supervisor and/or adhere to all relevant criteria and regulations. The Installer should consult an engineer for site assessment and correct installation methods.

When the pump is delivered, first perform the following checks.

INSPECTION

While unpacking, inspect the product for damage during shipment, and make sure all the fasteners, clamps, etc. are tightened properly.

SPECIFICATION CHECK

Check the model number to make sure it is the product that was ordered. Be certain it is the correct voltage and frequency.

PRODUCT SPECIFICATIONS

CAUTION

- Do not operate this product under any conditions other than those for which it is specified.
- Failure to observe this precaution can lead to electrical shock, electrical leakage, fire, water leakage, damage to property, injury and death.

INSTALLATION

CAUTION



Do not pump in liquids other than water, sewage, or chemically stable wastewater. Do not use pump in oil, salt water, flammable liquids, or organic solvents.

Use with a power supply voltage within +5% of the rated voltage.

- Do not use in water temperatures outside the range of 0-35°C. This can lead to failure, electrical leakage, shock or fire.
- Do not use in the vicinity of explosive or flammable materials, or areas classified as hazardous.
- Use only in fully assembled state

NOTE: Consult your dealer or representative before using with any liquids others than those indicated in this document.

PREPARING FOR INSTALLATION

Before installing the pump at a work site, you will need to have the following tools and instruments ready.

- Insulation resistance tester
- AC Voltmeter
- AC ammeter (clamp on type)
- Bolt and nut tighteners
- Power supply connection tools
- Ensure adequate power supply is available

NOTE: Please read also instructions that come with each of the test instruments.

CHECKS TO MAKE BEFORE INSTALLATION

When a three pin plug is used: Use the megohmmeter to measure the insulation resistance between the cable plug tips and ground.

When connection leads are used: With the megohmmeter, measure the insulation resistance between each core lead and the ground lead (Green/Yellow.)
Insulation Resistance must be in accordance with the applicable Australian Standard.

****DANGER!** Do not conduct electrical work unless you are a licenced Electrician.**

WARNING

- When installing the pump, pay close attention to its centre of gravity and weight. If it is not lowered into place correctly, it may fall and be damaged or cause injury.
- When transporting the pump by hand, be sure to employ manpower commensurate with the weight of the pump. To avoid back injury when lifting the pump, bend the knees to pick it up rather than bending your back.

CAUTION

- **Do not under any circumstances install or move the pump by suspending it from the power cable. The cable may be damaged causing electrical leakage, shock, fire, injury and death.**
 1. Attach the hose to the hose coupling as far as it will go, then fasten it securely with the hose band.
 2. Avoid dropping the pump or other strong impact. Lift the pump by holding it firmly with both hands or by attaching a rope or chain to the handle.
 3. Install the pump in an upright position on a secure base. Ensure that the inlet to the pump is not blocked by sludge, mud, solids, plastic bags, rubbish.
 4. Where a float switch is attached to the pump, ensure the float switch is free to operate without interfering with tank walls, pipe work etc.
 5. A swing check non-return valve and isolating valve should be fitted to discharge pipe close to the pump but accessible to that it can be replaced.
 6. The pump must not be used in or at swimming pools, garden ponds, or where there are people in the water.

CAUTION

- **Avoid dry operation, which will not only lower performance but can cause the pump to malfunction, leading to electrical leakage and shock**
 7. Install the pump in a location with sufficient water level, where water collects readily.

NOTE: Please refer to "Operating Water Level" (Page ...) for the water level necessary for operation

NOTE: The discharge end should be located higher than the water surface. If the end of the hose or pipe is submerged, water may flow back to the pump when the pump is stopped; and if the hose end is lower than the water surface, water may overflow when the pump is turned off.

CAUTION

- **If large quantities of earth are sucked up, damage resulting from erosion in the pump can lead to electrical leakage and shock**
 8. To prevent the pump strainer stand from becoming submerged in mud, causing it to suck in debris, mount it on a block or firm base

ELECTRICAL WIRING

WARNING

PERFORMING ELECTRICAL WIRING

- Electrical wiring should be performed by a qualified/licenced person in accord with all applicable regulations. Failure to observe this precaution not only risks breaking the law but is extremely dangerous.
- Incorrect wiring can lead to electrical leakage, electrical shock, fire, property damage, injury or death.
- Always make sure the pump is equipped with the specified overload protectors and fuses or breakers, as required by law, so as to prevent electrical shock from an electrical leak or pump malfunction.
- The voltage, frequency and current rating are displayed on the name plate, please ensure that the power supply meets the requirements.

WARNING

GROUNDING

- Do not use the pump without first earthing it properly. Failure to earth it can lead to electrical shock from an electrical leak or pump malfunction.

CAUTION

- Do not attach the earth wire to a gas pipe, water pipe, lightning arrestor or telephone earth wire. Improper earthing can result in electrical shock.

WARNING

CONNECTING THE POWER SUPPLY

- Before connecting leads to the terminal, make certain the power supply is turned off (circuit breaker, etc.), to avoid electrical shock, shorting, or unexpected starting of the pump, leading to injury or death.

WARNING

- Before inserting the power supply plug make certain the power supply is turned off (circuit breaker, etc.) to avoid electrical shock, shorting or unexpected starting of the pump, leading to injury or death.

CAUTION

- Do not use the pump with the power cable or plug connected loosely, which can result in electric shock, shorting, fire, injury or death.
- Draw power from a dedicated power outlet. Sharing the outlet with other equipment may overheat the branch outlet and could result in a fire.
 - When using a three pin plug, connect as described in the manufacturer's instructions.
 - When a single-phase power source is used, connect the leads to the control panel terminals as shown in the diagram, making sure they do not become twisted together.
- Be sure to use a dedicated power supply with a ground/earth leakage circuit breaker.

POWER CABLE

CAUTION

- If it is necessary to extend the power cable, use a core size equal to or larger than the original. This is necessary not only for avoiding a voltage drop, but to prevent a cable overheating which can result in fire, electrical leakage, electrical shock, injury and death. Refer to AS3000.
- If a cable with cut insulation or other damage is submerged in the water, there is danger of water seeping into the motor causing a short. This may result in damage to pump, electrical leakage, electrical shock, fire, injury or death.
- Be careful not to let the power cable be cut or become twisted. This may result in damage to the pump, electrical leakage, electrical shock, fire, injury or death.
- If it is necessary to submerge the connection leads of the power cable in water, first seal the leads completely in a molded sleeve, to prevent electrical leakage, electrical shock, fire, injury or death.
- Do not allow power cable leads or power supply plug to become wet.
- Make sure that the cable does not become excessively bent or twisted, and does not rub against a structure in a way that might damage.

ELECTRICAL CIRCUIT DIAGRAMS

SINGLE PHASE BELOW 1HP
(INCLUDE 1HP)

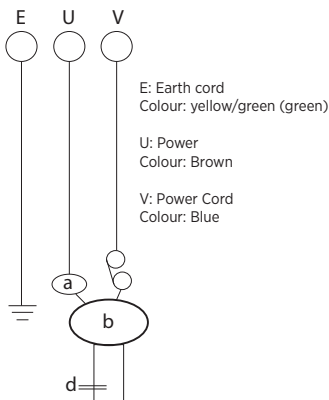

SINGLE PHASE ABOVE 1HP

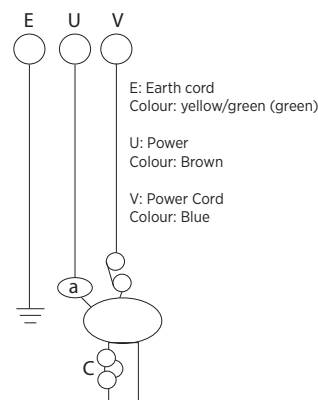

THREE PHASES

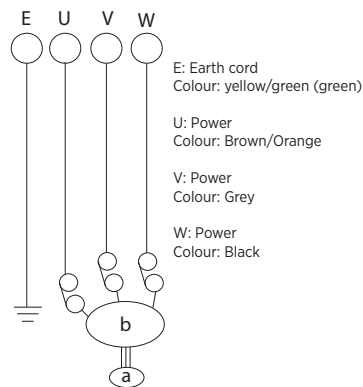

THREE PHASE PUMPS must be connected to an external motor starter fitted with a contactor and overload. The nominal current of the motor starter must correspond to the electrical data marked on the pump nameplate.

CHECKING THE DIRECTION OF ROTATION (THREE PHASE PUMPS ONLY)

The direction of rotation should be checked every time the pump is connected to a new installation.

Check the direction of rotation as follows:

At all times keep fingers and hands away from impeller.

- 1 Position the pump so that the impeller can be observed.
- 2 Start the pump momentarily, pump will jerk - be careful
- 3 Observe the rotation of the impeller. The correct direction of the rotation is indicated by an arrow on the top of the motor (anticlockwise when seen from the bottom.) If the impeller rotates in the wrong direction, reverse the direction of rotation by interchanging two phases of the motor.

If the pump is connected to a piping system, the direction of rotation can be checked as follows:

- 1 Start the pump and check the quantity of water or the discharge pressure.
- 2 Stop the pump and interchange two of the phases to the motor
- 3 Start the pump and check the quantity of water or the discharge pressure.
- 4 Stop the pump
- 5 Compare the results taken under point 1 and 3. The connection which gives the larger quantity of water or the higher pressure is the correct direction of rotation.

OPERATION

BEFORE STARTING

- 1 Make sure once again that the product is of the correct voltage and frequency rating

CAUTION

Using the product with a voltage and frequency other than the rated voltage frequency will not only lower its performance but damage the product.

NOTE: Confirm the rated voltage and frequency on the model name plate.

- 2 Confirm the wiring, supply voltage, circuit breaker capacity, and motor insulation resistance.

Reference insulation resistance: 20 or greater.

NOTE: The reference insulation resistance (20 or greater) is the value when the pump is new or has been repaired.

- 3 The setting on the circuit breaker or other overload protector should be made in accord with the rated current of the pump.

NOTE: See the model name plate on the pump for its rated current.

WARNING

TEST OPERATION

- Never operate the pump while it is suspended in the air. The recoil will result in injury, property damage or death.

- 1 Run the pump for a short time (3-10 minutes) and confirm the following:

- Using an ammeter (clamp-on type), measure the operating current at the L1, and L2 phase leads on the terminal.

Countermeasure: If the operating current exceeds the rated value, pump motor overload may be a cause, or there may be insufficient back pressure. Make sure the pump has been installed under proper conditions as described in installation (page 5.)

- Using an AC voltmeter (tester), measure voltage at the terminals.

Supply voltage tolerance: within +5% of rated voltage.

Countermeasure: If the supply voltage is outside the tolerance, possible causes are the power supply capacity or an inadequate extension cable. Look again at Electrical Wiring (page 8) and make sure the conditions are proper.

CAUTION

- In case of very excessive vibration, unusual noise or odour, turn off the power immediately and consult with your nearest dealer or representative. Continuing to operate the pump under abnormal conditions may result in electrical shock, fire property damage injury or death.
- 2 If the test operation reveals no problems, continue operating the pump.

WARNING

- Do not operate the pump in dry pit, well, trench etc.
- The pump may become very hot during operation. To avoid being burned, be careful not to contact the pump accidentally
- Make sure no extraneous objects such as pins, nails, or other metal objects, cloth wipes, rocks, wood, napkins or sanitary items or products of this nature are sucked into the pump. These can damage the pump or cause it to malfunction, and can result in electrical shock or electrical leakage
- In case of a power outage, turn off the power to the pump to avoid having it start unexpectedly when the power is restored, presenting serious danger to people in the vicinity.
- Pay careful attention to the water level while the pump is operating. Dry operation may cause the pump to malfunction.

NOTE: See page ..., "Operating Water Level" for water level necessary for operation

- Sharp bends in the hose, especially near its base may cause air pockets to form resulting in idle operation. Lessen the degree of bending while continuing to operate the pump.

CAUTION

Do not operate the pump below C.W.L (Continuous running water level.) Failure to observe this condition may result in damage to pump, electrical leakage or electrical shock.



MOTOR PROTECTION SYSTEM (Autocut Protector)

Some single phase pumps have a built-in motor protection system (Autocut Protector.) If an excessive current is detected or the motor overheats, for reasons such as the following, the pump will automatically, stop operating regardless of the water level, to protect the motor.

- Change in supply voltage polarity
- Overload
- Open-phase operation or operation under constraint

NOTE: Always determine the cause of the problem and resolve it before resuming operation. Simply repeating cycles of stopping and restarting will result in damage to the pump. Do not continue operation at a very low lift, low water level, or while the strainer stand is clogged with debris. Not only will performance suffer, but such conditions may cause noise, heavy vibration, and malfunctioning.

MAINTENANCE AND INSPECTION

Regular maintenance and inspections are necessary for continued efficient functioning of the pump. If any abnormal conditions are noticed, refer to the section on Troubleshooting (pages 12-13) and take corrective measures immediately.

It is highly recommended that a spare pump be kept ready in case of any problems.

WARNING

PRIOR TO INSPECTION

- Consult WHS supervisor for correct procedures
- Detach the power cable from the receptacle or terminals, after making certain the power supply (circuit breaker, etc.) is turned off. Failure to follow this precaution will result in a serious accident or death from electrical shock or unexpected starting of the pump motor.

1 Washing the pump: Remove accumulated matter from the surface of the pump and wash it clean water. Take special care to remove any debris from the impeller.

2 When inspecting the pump exterior look for any peeling or chipped paint, and make sure the nuts and bolts are fastened tightly. Any cracks in the surface should be repaired by cleaning up that area, drying it and then applying touch up coating.

NOTE: Touch up is not supplied. Note that some kinds of damage or looseness may require that the unit be dismantled for repairs. Please consult with your nearest dealer.

Frequency	Inspection Items
MONTHLY	Measure insulation resistance - Reference resistance 1 --- or greater NOTE: If the insulation resistance has become notably lower than previous inspection, an inspection of the motor will be necessary. <ul style="list-style-type: none">• Measure operating current - compare with rated current• Measure supply voltage - Compare with allowable range (within +5% of rated voltage)• Pump inspection• A noticeable drop in performance may indicate wear in the impeller, etc. or else clogging of the strainer stand, etc. Remove clogged debris, and replace any worn parts.
BI-ANNUALLY	<ul style="list-style-type: none">• Oil inspection• Check the oil every six months or after 1,000 hours of use, whichever comes first.
ANNUALLY	<ul style="list-style-type: none">• Change oil• Change oil every 12 months or after 2,000 use, whichever comes first.• Designated oil: Turbine Oil VG32 - Caltex - or similar• Change mechanical seal. <p>NOTE: Trained personnel are required for inspecting and replacing the mechanical seal. Consult with your nearest dealer or representative.</p>
2-5 YEARS	Overhaul - this should be carried out even if there are no other problems with the pump. The frequency depends on how continuously the pump is in use. NOTE: Consult with your nearest dealer.

STORAGE

When the pump is out of use for an extended period, wash it and dry it thoroughly, then store it indoors.

NOTE: Always run a test operation before putting the pump back into service.

When the pump is left installed in the water, it should be run at regular intervals (about once a week.)

OIL INSPECTION & CHANGE

- **Inspecting Oil**
Remove the Oil Plug (Hex. Bolt) and tilt the pump to drain a small amount of oil. If the oil is milk white or has water mixed with it, the Mechanical seal maybe faulty. In this case the pump will need to be dismantled and repaired.
- **Replacing the Oil**
Remove the Oil Plug and drain all the oil, then replace it with the specified amount.
NOTE: Used oil and other waste products should be disposed of by a qualified agent, in accord with applicable laws. The Oil Plug packing and O-Ring should be replaced each time the oil is inspected or changed.

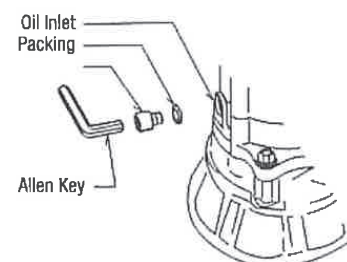

TROUBLESHOOTING

TROUBLE	CAUSE	REMEDY
Does not start. Starts, but immediately stops.	<ol style="list-style-type: none"> 1. Power Failure 2. Large discrepancy between power source and voltage 3. Significant drop in voltage 4. Motor Phase malfunction 5. Electric circuit connection faulty 6. Faulty connection of control circuit 7. Fuse blown 8. Faulty magnetic switch 9. Water is not at level indicated by float 10. Float is not at appropriate level 11. Float defective 12. Short circuit breaker is functioning 13. Foreign matter clogging pump 14. Motor burned out 15. Motor bearing a failure 	<ol style="list-style-type: none"> 1-3. Contact electric power company and devise counter measures 4. Inspect connections an magnetic switch 5. Inspect electric circuit 6. Correct wiring 7. Replace with correct type of fuse 8. Replace correct type of magnetic switch 9. Raise water level 10. Move float to appropriate starting level 11. Repair or replace 12. Repair location of short circuit 13. Remove foreign matter 14. Repair or replace 15. Repair or replace
Operates, but stops after a while.	<ol style="list-style-type: none"> 1. Prolonged dry operation has activated motor protector and caused the pump to stop. 2. High liquid temperature has activated motor protector and caused the pump to stop 	<ol style="list-style-type: none"> 1. Raise stop water level 2. Lower liquid temperature
Does not pump. Inadequate volume.	<ol style="list-style-type: none"> 1. Reverse Rotation 2. Significant drop in voltage 3. Operating a 60Hz pump on 50Hz 4. Discahrge head is high 5. Large piping loss 6. Low operating water level causes air suction 7. Leaking from discharge piping 8. Clogging of discharge piping 9. Foreign matter in suction inlet 10. Foreign matter clogging pump 11. Worn impeller 	<ol style="list-style-type: none"> 1. Correct rotation (operation 2,3) 2. Contact electric power company and devise counter meares 3. Check nameplate 4. Recalculate and adjust 5. Recalculate and adjust 6. Raise water level or lower pump 7. Inspect, repair 8. Remove foreign matter 9. Remove foreign matter 10. Dissassemble and remove foreign matter 11. Replace impeller
Over Current	<ol style="list-style-type: none"> 1. Unbalanced current and voltage 2. Significant voltage drop 3. Motor phase malfunction 4. Operating 50Hz pump on 60Hz 5. Reverse rotation 6. Low head, Excessive volume of water 7. Foreign matter clogging pump 8. Motor bearing is worn or damaged 	<ol style="list-style-type: none"> 1. Contact electric power company and devise counter measure 2. Contact electric power company 3. Inspect connections and magnetic switch 4. Check nameplate 5. Correct rotation (see page 7) 6. Replace pump with low head pump 7. Disassemble and remove foreign matter 8. Replace bearing
Pump Vibrates; excessive operating noise.	<ol style="list-style-type: none"> 1. Shut off valve closed too far 2. Piping resonates 3. Reverse rotation 	<ol style="list-style-type: none"> 1. Open shut off (valve) 2. Improve pipe mounting 3. Correct rotation (see page 7)

WARNING

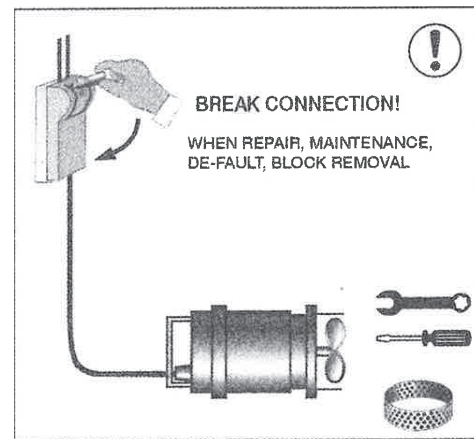
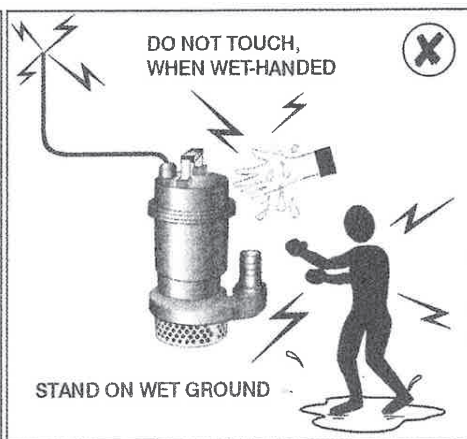
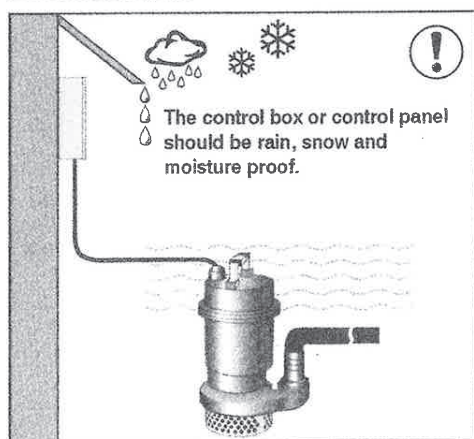

POWER-OFF immediately, in case of the following cases (X)

OVER-HEAT



ABNORMAL VIBRATION OR CRANKING

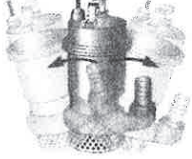

BAD SMELL, SMOKE

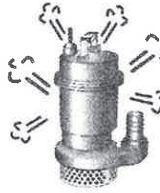

ABNORMAL SOUND

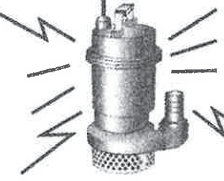

BREAKER SET (X)

DO NOT CUT-OFF GROUND PRONG OR GROUND WIRE

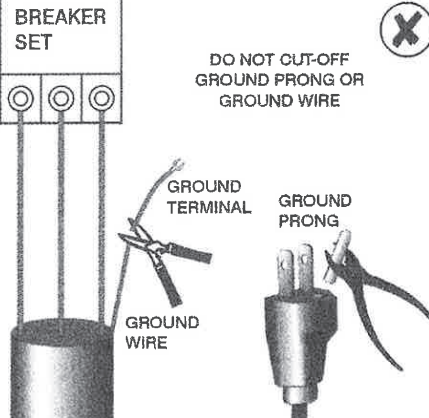

GROUND TERMINAL

GROUND WIRE

GROUND PRONG

(X)

DO NOT POWER-ON when water is iced or frozen



DO NOT PASS the cable through OILY ground or on which full with sharp objects, chemical material etc. (X)

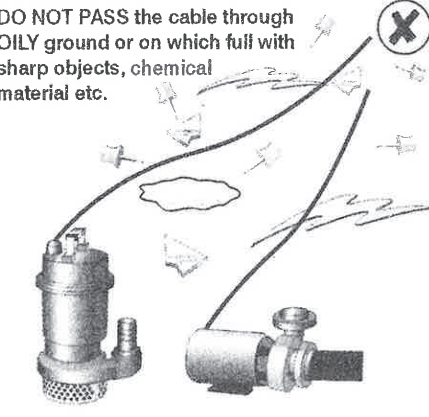

DO NOT USE if cable is of: (X)

NAKED COPPER WIRE



CRACKED CABLE SKIN



POOR OF CONNECTION, SEPERATION, INSULATION

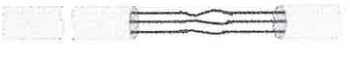

DO NOT DRAG PUMP by cable (X)



(X)

DO NOT Lift or carry by pulling the cable

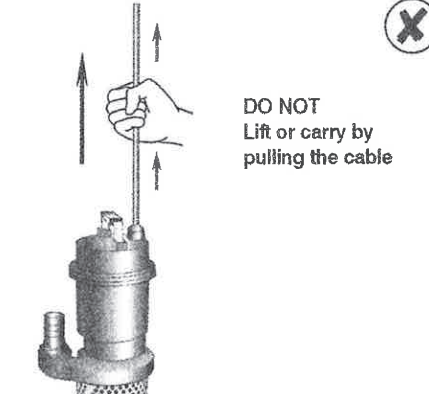

DO NOT USE too long cable (X)

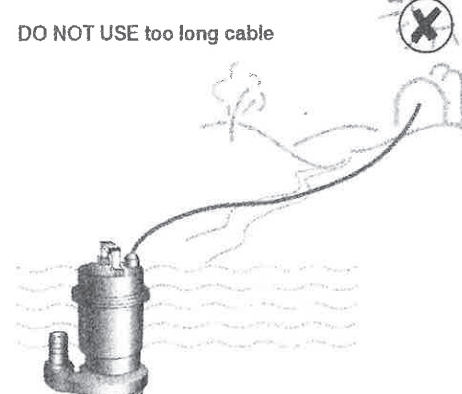

WARNINGS & IMPORTANT INFORMATION

- 1. (A) PIPE SIZE & PIPE TYPE: Install the pump as near as possible to the discharge to reduce the length of delivery pipe. Use as few bends as possible, every bend reduces performance. (B) MORE INFO RE PIPE SIZE: Ensure the pipe is optimized for the Head (lift) and Flow and Velocity required. Pipes that are too small means more power will be used as the pump has to work harder to overcome the extra back-pressure from small pipes. A small short-term (in the cost of the pipes) will become a long-term liability
2. SEAL JOINTS: Ensure all fittings and joints are watertight and airtight.
3. INSTALLATION AND ELECTRICAL WIRING: Must adhere to state and local codes and must be completed before using the pump. All pumps come with an earth cable and all electrical installations must be earthed. Any electrical work must be performed by a licenced Electrician. The installation must also comply with applicable Plumbing Regulations, it is the installers responsibility to ensure compliance.
4. IMPORTANT RE SAFETY SWITCH (RCD): (A) 240V Pumps must be connected to a suitable power circuit with an integral RCD (safety switch) having a rated residual operating current not exceeding 30mA, in the circuit breaker. Disconnect the pump from power supply when people are in the water, or when servicing or repairing the pump. All warranty is voided if this instruction is not followed. Note: Plugging into existing outlets may cause low voltage supply to the motor, causing blown fuses, tripping of motor overload, or burnt out motor, which will not be covered by the Warranty. (B) 415V Pumps must be installed by a licenced Electrician, in compliance with the applicable Electrical Regulations & Australian Standards.
5.VOLTAGE: of power supply must match the voltage of the pump. Do not run on generator power from low quality/old generators. High quality "Sine-Wave" generators are usually acceptable but we cannot guarantee this, as we have no control over the generator that you use, it is your responsibility to ensure the generator used is fit for the purpose.
6. WARNING: These pumps are not designed for, and must not be installed in locations classified as hazardous.
7. THE FOLLOWING MAY CAUSE SEVER DAMAGE TO THE PUMP AND WILL VOID WARRANTY: a. Using an extension cord to power the pump b. Cutting the earth pin off the plug or using an adapter fitting or double adapter. c. Working on the pump while connected to the power supply. d. Removing motor housing, or disassembling the pump housing, except by a qualified technician. e. Pumping chemicals or corrosive liquids or flammable liquids. f. Pumping hot liquids (Exceeding 35° Centigrade) g. Using a generator for power supply h. Operations that involve frequent starting. This will lead to premature failure of the capacitor i. Dry operation will destroy the pump seals and is not covered by warranty

WARNING!

ELECTRICAL PRECAUTIONS

DO NOT INSTALL PUMP if the premises does not have a Safety Switch (RCD)

Before servicing a pump, always shut off the power supply and then make sure you are not standing in water and that there is no risk of electrical shock. If pump is direct-wired to the electrical circuit, have a qualified licensed electrician disconnect it before attempting any repairs or servicing.

DO NOT ATTEMPT ELECTRICAL REPAIRS OF ANY SORT UNLESS YOU ARE A LICENSED ELECTRICIAN

WARRANTY RECORD - FILL IN AND RETAIN THIS WITH YOUR ORIGINAL PURCHASE RECEIPT

PURCHASER NAME & ADDRESS..... PHONE NO.....
DATE OF PURCHASE/...../..... DEALER/STORE NAME.....
DEALER SUBURB/TOWN..... PHONE NO.....
BRAND & MODEL NUMBER OF PUMP..... BATCH or SERIAL NUMBER.....
Do NOT send this form to us, retain it for your record.

INSTALLATION CHECKLIST: MUST BE FILLED IN FOR WARRANTY TO APPLY

Installer Name _____ Qualification: _____ (write Owner if applicable)
Phone Number: _____ If installed by a Plumber or Electrician, Licence No: _____
Installation Address: _____

- Tick the boxes as the item is completed/correct, put n/a if not applicable;
[] The Pump is being used for an appropriate purpose for which it is intended, according to the instructions
[] The Power Circuit the Pump is connected to is RCD (Safety Switch) Protected
[] Barrel unions or similar are fitted on the pipe connections for easy removal & replacement
[] A Swing Check valve is fitted to prevent back-flow
[] Pipe is sized appropriately for the application (diameter & length)
[] The installation is constructed so the pump can be easily removed or replaced.
[] The pump is installed in accordance with National & Local Plumbing Regulations
[] The Electrical Suppyl cable is plugged into a Power Outlet that is in accordance with the current standard of Electrical Safety Regulations AS/NZS 3000 - or the pump has been wired directly to the power circuit by a Licenced Electrician
[] The pump has been tested with water in the sump / pit / pump-well, and operates correctly
[] The pipes and connections have been checked for leaks
[] The pump is protected from sunlight, with a suitable vented cover or enclosure.

Signed by the Installer: _____ Date Installed: / /

WARRANTY CONDITIONS

1. Our goods come with guarantees that cannot be excluded under the Australian Consumer Law. If you are a consumer as defined by the Australian Consumer Law, you are entitled to a replacement or refund for a major failure and for compensation for any other reasonably foreseeable loss or damage. You are also entitled to have the goods repaired or replaced if the goods fail to be of acceptable quality and the failure does not amount to a major failure. If you (the purchaser) do not fall within the meaning of "consumer" in the Australian Consumer Law the provisions of the Australian Consumer Law may not apply. The following conditions form part of the instructions and do not over-ride your statutory rights.
2. This warranty covers failure due to manufacturing defects for Sump Pumps (including but not limited to the series listed below, according to our interpretation as to what is and is not covered) that are purchased and used in mainland Australia. We shall repair or replace faulty goods when we ascertain that the fault is due to manufacturing defects, within the period of time as advised by us for any particular item. If you require a refund, return the item to the original place of purchase.
3. Faults or losses or failure or damages are not covered by warranty where caused due to: Accidents, misuse, lack of maintenance, using with unsuitable substances, not following these instructions, damage caused by lightning strike/power surges/spikes/brownouts, operating the pump on power other than 230-240volts 50Hz mains power, or any other unforeseen or unexpected event or cause that is beyond our control.
4. Where fitted and where applicable: The complete Impeller set (including shaft), Pre-filter Sponge, Seals and O-rings are all wearing items and therefore are not covered for "normal wear and tear". They are covered by this warranty if they are faulty due to a manufacturing defect.
5. Warranty will be void if any tampering or removal of identification labels or electrical cables has occurred, or any non-genuine parts have been fitted, or repairs have been carried out by unqualified persons. No warranty applies for goods sold or used for HIRE or RENT or LEASE. No warranty applies, and no liability is accepted, if the pump is used in circumstances that we define as: HAZARDOUS SITUATIONS, MINE SITE, REMOTE AREA, INDUSTRIAL APPLICATION, or any other UNSUITABLE APPLICATION, all of these circumstances are defined by us at our sole discretion.
6. The Warranty excludes accidental or deliberate breakages, normal wear and tear, fading or breakdown due to the effect of exposure to sunlight or chemicals, corrosion due to chlorine in the water, or any other external factor that may affect the life of the product.
7. This product is guaranteed as fit for the purpose of pumping CLEAN WATER, STORM WATER and GREY WATER in normal domestic household use, and for NO OTHER USE. This pump is not intended for Potable Water, it has not been tested for Potable Water. Performance data quoted is generally from test data and is approximate and does not take into account factors in the installation such as loss of pressure and flow due to pipework & pipe-fittings & valves. It is the purchaser's responsibility to ensure that the product is fit for their purpose and of sufficient size & performance for their application.
8. IMPORTANT: No electrical appliances last forever. Therefore ALL installations of these pumps must be constructed to allow the owner to easily remove the pump for servicing, and to easily remove the pump for replacement, warranty replacement or upgrading. Warranty replacement does not include costs of removal and re-installation as we have no control over the method of installation.
9. Before installing or servicing disconnect from the power supply.
10. This pump is not to be used as your sole water supply. For critical applications where loss of water supply for pump failure could cause serious consequences, use a DUAL PUMP System so that you have a backup pump.
11. This pump must be installed in accordance with these instructions, and the Installation Checklist must be filled in and signed for warranty to apply. The Pump MUST NOT be installed in any manner that if it were to leak, or fail to work, that it would cause damage or loss to property or persons. It MUST be installed in a well-ventilated and drained area. All warranty is void if this condition is not heeded and no liability can be accepted in the case of damage or loss caused by failing to comply with this condition.
12. The Pump must be correctly earthed and connected to a circuit with an integral RCD (safety switch) in the circuit breaker, in accordance with the Electrical Regulations or Standards that are applicable.
13. In the case of a fault, refer to the Trouble Shooting Guide first. If these steps do not rectify the problem, then return the faulty appliance to the original place of purchase with proof of purchase for replacement or refund. Alternatively you can mail us at PO BOX 650 MORNINGSIDE QLD 4170 or send an email to csv@ascento.com.au with a photo of the faulty item, copy of your purchase receipt, a copy of the installation checklist, a description of the problem, and your name and address and phone number - we will review your request and send you a replacement directly if we accept your warranty claim. Or call us on 1800 807 604 with the above information; however we will always require a copy of your purchase receipt and the installation checklist. Do not send the product to us unless we ask you to do so. Please note that guarantees and warranties only apply when the installation and use of the product is suitable according to our definition. Prior to processing or accepting any claim against us, of any type, we reserve the right to inspect either in person (with owners permission), or by use of a drone or any other method of our choice (with owners permission), or request photographs and/or video evidence, or request for the product to be returned to our premises for inspection. If the owner does not allow us these rights of inspection, we are unable to process any claim.
14. Pumps used in SUITABLE commercial or industrial applications are covered by a replacement warranty only, when proved to have a manufacturing defect that has caused the pump to fail. No warranty applies when used in unsuitable applications, which shall be defined by us, at our sole discretion.
15. If an exact replacement is not available, the closest equivalent product will be supplied at our discretion.
16. This warranty does not exclude any non-excludable rights according to Australian Law. However any condition that is made void by Australian Law does not void the remaining conditions, which shall stand unaltered.

© COPYRIGHT 2020 No part of this publication is to be copied stored or distributed in any manner or form without the prior written permission of Ascento Group Australia. E&EO. PRIVACY STATEMENT: We will not use your name, address, phone or fax number, or email address for marketing, nor sell or provide it to any other third party for the purpose of marketing.