



PUMPS AUSTRALIA

BETTER • FASTER • EASIER



## EXTERNAL RAIN MAINS SYSTEM

EXPLODED VIEW &  
INSTRUCTION MANUAL

**MODEL:** RM4000-5

**PUMP:** PRESSURE PUMP WITH RM1500-2 VALVE

# COMPONENTS & MATERIALS

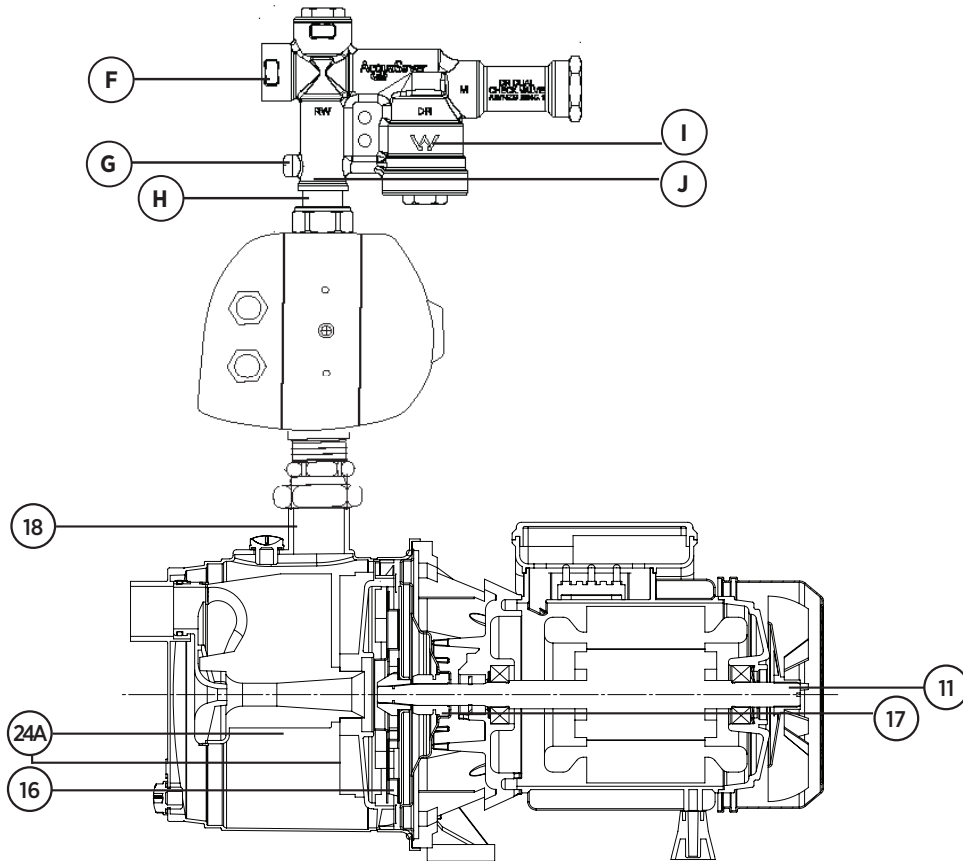

POSITION	COMPONENT	MATERIAL
11	Pump Shaft	Stainless Steel AISI 420F
14A	Motor Bracket Kit	In die casting alumnium UNI 5076
16	Impeller	Techno Polymer
17	Mechanical Seal	Carbon - Ceramics
18	Pump Body	Stainless Steel AISI 304
24A	Diffuser, Nozzle & Venturi	Techno Polymer
F	RM1600-2 Body	DZR Brass
G	1/8 BSP Plug	Stainless Steel
H	Brass Tail	DZR Brass
I	End Cap	DZR Brass
J	DN25 Nut	Brass

## RM1500-2 | RM1600-2

### EXTERNAL PUMP SYSTEM WITH PRJE AND RAINPRO RM1500-2 or RM1600-2 RAIN TO MAINS BACKUP VALVESET

**\*\*PLEASE LEAVE THIS GUIDE IN A SAFE PLACE FOR THE OWNER\*\***

#### IMPORTANT INSTALLATION GUIDELINES

Mandatory installation condition: the premises where the pump is installed, and the power circuit to which it is connected, must be protected by an rcd (safety switch) – do not install pumps without this protection.

- All parts shown are WaterMarked & certified for Potable Water
- Fittings may differ from the image shown due to variations in design
- Do not adjust the PRV, warranty is void if adjusted
- **Read and follow the instructions in the pages following**

**IMPORTANT:** If installing close to a wall or other fixture, use barrel-union connections to allow removal if ever required.

**W**® WMK LICENCE:  
WM-022109  
AUSTRALIAN STANDARD:  
WMTS-477

WaterMark Quality System Doc # RQS.1059 Ver.20190925

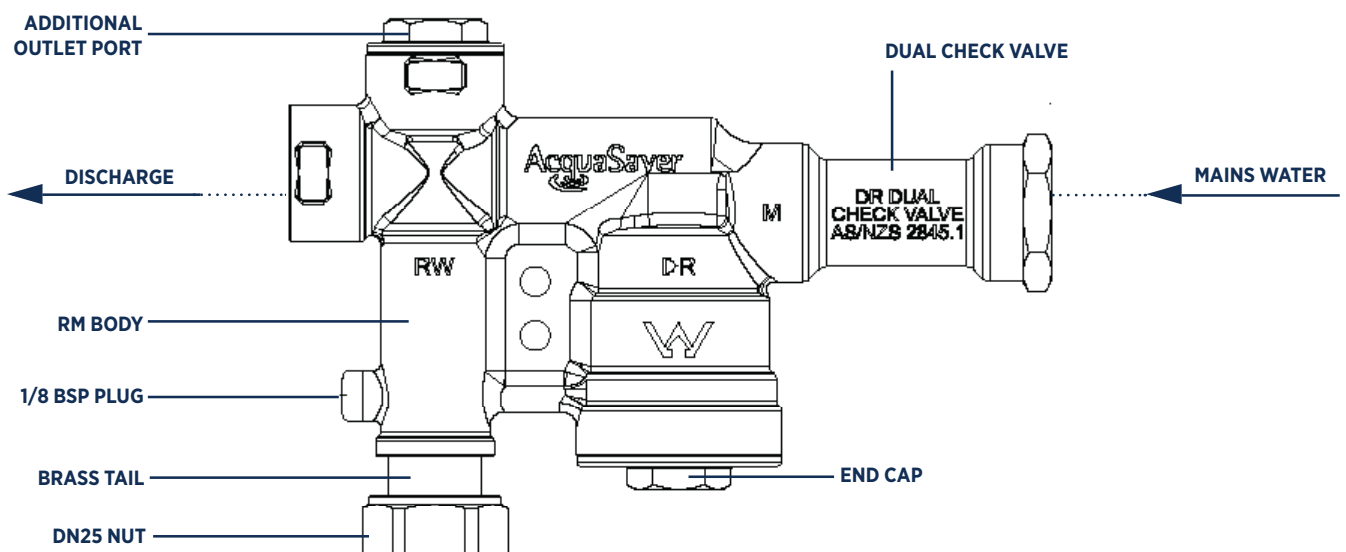

# INSTALLATION INSTRUCTIONS

## RM1500-2 | RM1600-2 VALVES

### INTRODUCTION

The RM1500-2 and RM1600-2 Valves are fully automatic mechanical rainwater/mains water changeover devices designed for pressure pump supply systems for harvesting rainwater for the toilet, laundry and household applications with automatic mains backup. It is suitable for up to 2 toilets and washing machine and an extra tap outlet

### FEATURES

- Easy to install
- Patent design
- Solid Brass mounting bracket (optional)
- Watermark approved to WMTS477/LN60075
- Does not require regular maintenance
- No electrical consumption - No electronic components
- Solid brass construction - Fully weatherproof -Built to last
- Suitable for any pressure pump with sufficient head pressure
- Can be mounted in any position
- Built-in dual check valve for backflow prevention
- 2 Year warranty

### OPERATION

The RM1500-2 and RM1600-2 Valves will always prioritize the use of rainwater over mains water when rainwater is available and will automatically switch over to mains water in the event of the rainwater tank running low or electrical failure. When rainwater has been replenished or power has been restored to the pump, the RM1500-2 and RM1600-2 valves will automatically prioritize back to rainwater. The pump is only active when rainwater is being drawn from the water tank, it does not operate when the RM1500-2 and RM1600-2 Valve has switched to mains position.

The pump controller starts and stops the pump when it detects a demand - for example flushing a toilet or using a washing machine. The operating mechanism of the RM1500-2 and RM1600-2 Valves are a unique patent design, it works by hydraulic water pressure created by the pump to close one inlet fully before opening the other inlet. This ensures an extremely reliable mechanism using few moving parts and no electronic components and no energy consumption.

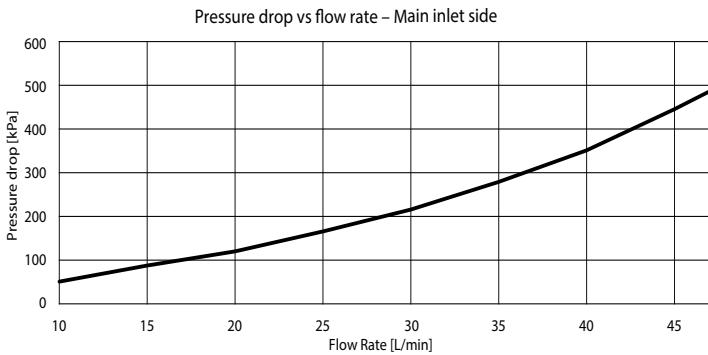

Pressure drop versus flow rate between the mains water inlet side and the outlet of the device

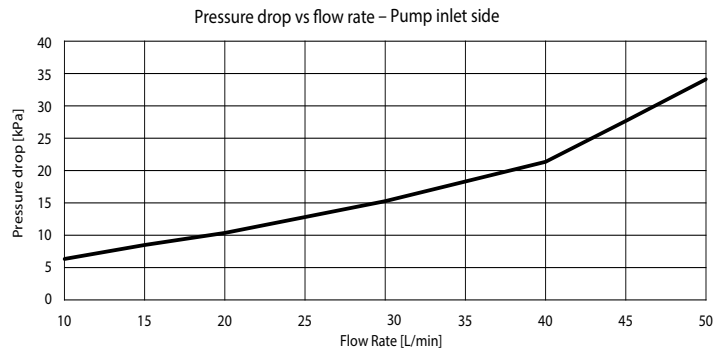

Pressure drop versus flow rate between the rainwater inlet side and the outlet of the device

### CONNECTION

All plumbing connections should be carried out by a licensed plumber.

#### Step 1.

The RM1500-2 or RM1600-2 Valve is fitted onto the pump controller as shown in Fig 1. Lock up the 1" BSP F loose nut with the rubber washer supplied, do not over tighten.

#### Step 2.

Connect mains water to the RM1500-2 or RM1600-2 Fig 2.

#### Step 3.

Connect outlet to the premises.

**Fig 3.** Shows a typical installation for a submersible pump.

**Fig 4.** Shows the RM1500-2 or RM1600-2 mounted to the wall/ other surface using the optional bracket

#### NOTE:

The RM1500-2 or RM1600-2 Valve can be installed in any position and location, it does not require to be installed on the pump as shown in diagram. Connection of the pump should be carried out to manufacturer's instructions, it is recommended that a Y-Strainer be fitted between the tank and pump.

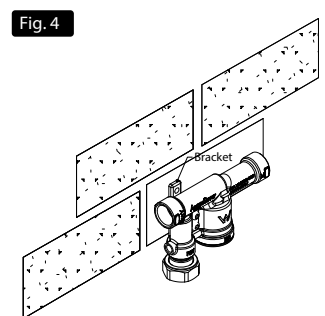
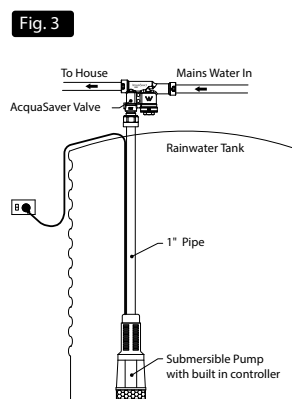
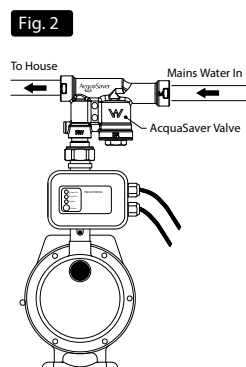
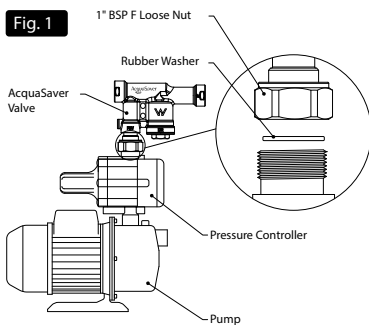

## SPECIFICATIONS

Meets Requirements of WMTS477/LN60075

Complies to WMTS477/LN60075 when installed by a licensed plumber

NOTE: According to WMTS477/LN60075 maximum allowable pressure in buildings is 500 KPa

\*Ensure proper protection against freezing weather. Complies to AS/NZS 3500.1 when installed by a licenced plumber

	RM1500-2	RM1600-2
Max Mains Pressure	500KPa	500KPa
Max Pump Pressure	600KPa	600KPa
Min Pump Pressure	350KPa	300KPa
Max Flow Rate	100L/Min	50L/Min
Max Water Temperature	50C	40C
Min Water Temperature	0C	0C
Pump Inlet	25mm, 1" FBSP	25mm, 1" FBSP
Mains Water In	25mm, 1" FBSP	25mm, 1" FBSP
Outlet	25mm, 1" FBSP	20mm, 3/4" FBSP
Weight	1.6Kg	0.85Kg

## IMPORTANT INSTALLATION & WARRANTY CONDITIONS - EXTERNAL PUMPS

- 1) The mains supply must not exceed 500kPa refer AS/NZS 3500.1
- 2) The pump must have flooded suction (gravity feed of tank-water) with an inlet pipe not less than the size of the pump inlet (typically 25mm)
- 3) The suction must have a Y-Strainer fitted (on the inlet from tank)
- 4) Mains supply must have an isolation valve (ball-valve)
- 5) Tank supply must have an isolation valve (ball-valve)
- 6) ALL CONNECTIONS must be with Barrel-Unions
- 7) Most pump warranties are conditional upon a pump cover being fitted

## IMPORTANT INSTALLATION & WARRANTY CONDITIONS - SUBMERSIBLE PUMPS

- 1) The mains supply must not exceed 500kPa refer AS/NZS 3500.1
- 2) The pump must be easily accessible for repair or servicing
- 3) If the pump has a float switch, ensure it CANNOT get stuck on the side of the tank or under baffles or similar -warranty service does not cover this situation.
- 4) Mains supply must have an isolation valve fitted (ball-valve)
- 5) ALL CONNECTIONS must be with Barrel-Unions
- 6) For underground tanks, the installation must be designed and constructed to allow easy access, for removal or replacement of the pump, warranty does not include costs of digging up gardens etc!

## TROUBLESHOOTING

SYMPTOM	CAUSE	REMEDY
No water is delivered from pump or pump performance is decreased	Rainwater tank is empty. No Power. Isolation Valve is shut. Pump is not primed. Y-Strainer is blocked.	Wait for tank to fill. Check power supply & plug. Restart pump. Open isolation Valve. See pump owners manual on priming pump. Clean Y-Strainer.
No water is delivered from mains	No water from mains. Debris in valve.	Check isolation valve on water meter. Open bleed plug
Pump continually runs	Leak in the plumbing system. E.g. Toilet or tap leaking. Faulty pump	Repair Leak. Contact pump manufacturer.

## MAINTENANCE

The RM1500-2 or RM1600-2 Valve does not require any regular maintenance however there are things you can do to ensure its most reliable operation.

- Fit a Y-Strainer
- Cleaning your gutters
- Cleaning the inlet strainer on rainwater tank

## WARRANTY INFORMATION

RM1500-2 and RM1600-2 warranty for Australia and New Zealand

The RM1500-2 and RM1600-2 valve is guaranteed for a period of 2 years from the date of original purchase to be free of material or manufacturing defects. Should any part fail as a result of such defects within this period, the RM1500-2 and RM1600-2 valve will be repaired or replaced by the manufacturer, free of charge. The RM1500-2 and RM1600-2 valve also has a LIMITED LIFETIME WARRANTY on all brass components, any brass component will be replaced free of charge if it fails in normal use during its life.

This warranty applies in all states and territories in Australia and New Zealand. The warranty period commences on the day of the original purchase of the RM1500-2 and RM1600-2 valve. Evidence of this purchase must be provided when claiming repairs or replacement, it is recommended you retain all receipts. Both warranties are subject to conditions by the original purchaser with all conditions set out in the installation and operating instructions. Failure to comply with these instructions, damage or breakdown caused by fair wear and tear, negligence, misuse, incorrect installation, chemical or additives in the water, corrosive or abrasive water, inadequate conditions, attempting repairs or accidents, are not covered by this warranty.

Our goods come with guarantees that cannot be excluded under the Australian Consumer Law. If you are a consumer as defined by the Australian Consumer Law, you are entitled to a replacement or refund for a major failure and for compensation for any other reasonably foreseeable loss or damage. You are also entitled to have the goods repaired or replaced if the goods fail to be of acceptable quality and the failure does not amount to a major failure. The above conditions form part of the instructions and do not over-ride your statutory rights.



## CORRECT INSTALLATION

### IMPORTANT!

FLOODED SUCTION ONLY! THE TANK WATER MUST BE "GRAVITY FED" TO THE PUMP. THE SYSTEM WILL NOT FUNCTION CORRECTLY WITH SUCTION LIFT.

### CONDITION OF WARRANTY

ALL INSTALLATIONS MUST INCLUDE:  
(1) BARREL UNION  
(2) Y-STRAINER OR PRE-FILTER  
(3) BALL VALVE OR GATE VALVE

MAX MAINS PRESSURE 500KPA

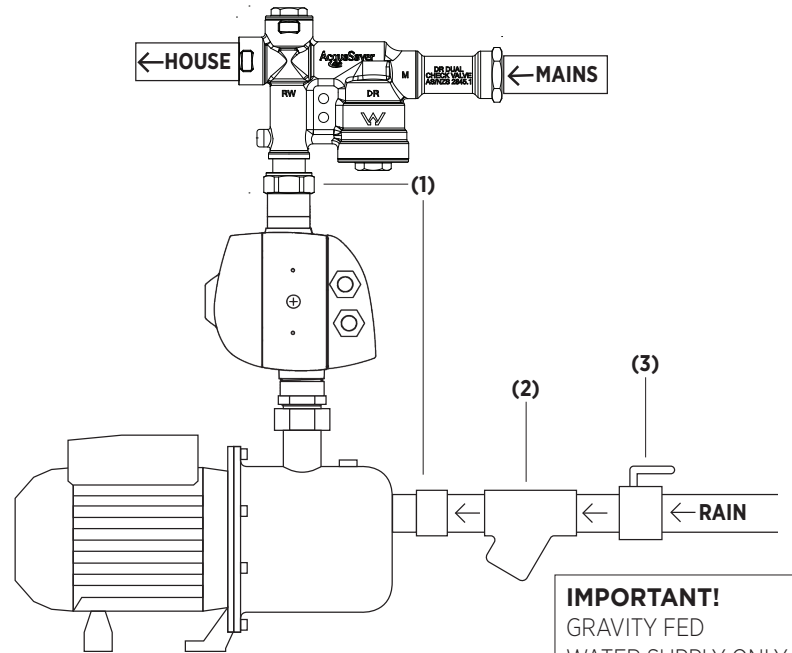

**IMPORTANT!**  
GRAVITY FED  
WATER SUPPLY ONLY



## INCORRECT INSTALLATIONS

**X NO**

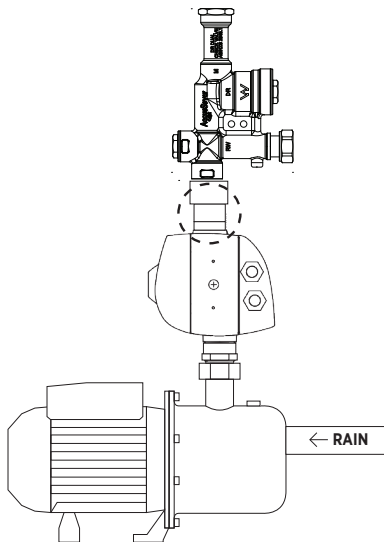

**X NO**

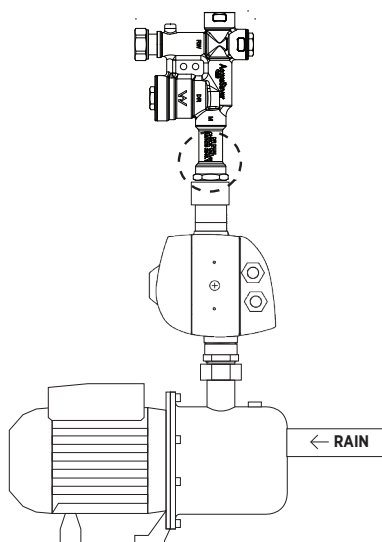

**X NO**

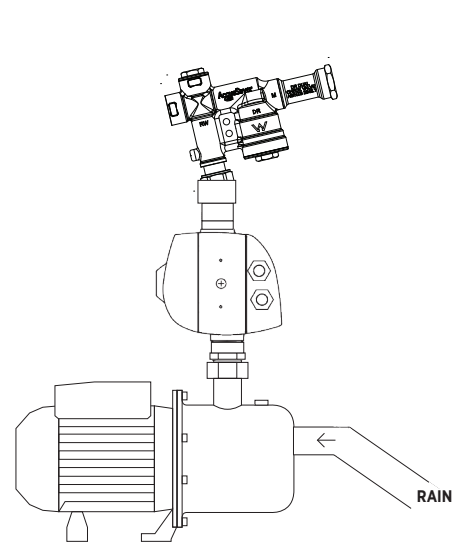

OVER  
500KPA

**X NO**

MAINS WATER

AS PER AS3500.1 MAINS MUST NOT BE OVER 500KPA





**CONDITION OF WARRANTY**

ALL INSTALLATIONS MUST INCLUDE:

- (1) BARREL UNION
- (2) Y-STRAINER OR PRE-FILTER
- (3) BALL VALVE OR GATE VALVE

**TIP**

PRESSURE TANKS SAVE YOU MONEY AS THE PUMP DOES NOT HAVE TO START SO OFTEN

**TIP**

CLEAN THE Y-STRAINER MONTHLY TO ENSURE PEAK PERFORMANCE. SIMPLY UNDO THE BUNG AND LET IT FLUSH OUT. MAKE SURE YOU RE-FIT THE MESH FILTER

**TIP**

IF THE PUMP STARTS FREQUENTLY, CHECK TOILET CISTERNS, THEY ARE PROBABLY LEAKING.

**IMPORTANT**

RAIN-MAINS SYSTEMS ARE NOT TO BE USED WITH SUCTION LIFT UNLESS A PUMP SHUT OFF CONTROLLER IS ADDED

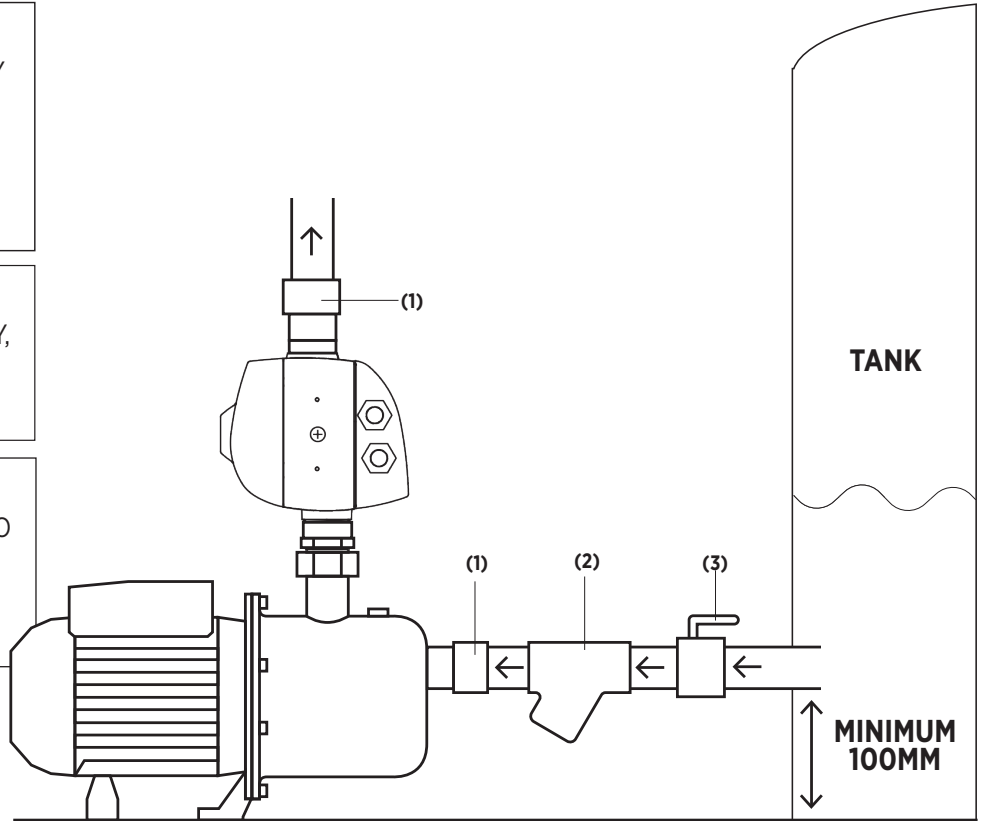

**IMPORTANT**

ALWAYS PRIME THE PUMP BEFORE STARTING

**TIP**

SOMETIMES YOU MAY HAVE TO DO THIS AFTER THE PUMP HAS STOPPED DUE TO THE TANK BEING EMPTY OF LOW IN WATER

**TIP**

IF YOUR PUMP STOPS, CHECK YOUR TANK, IT MAY BE EMPTY

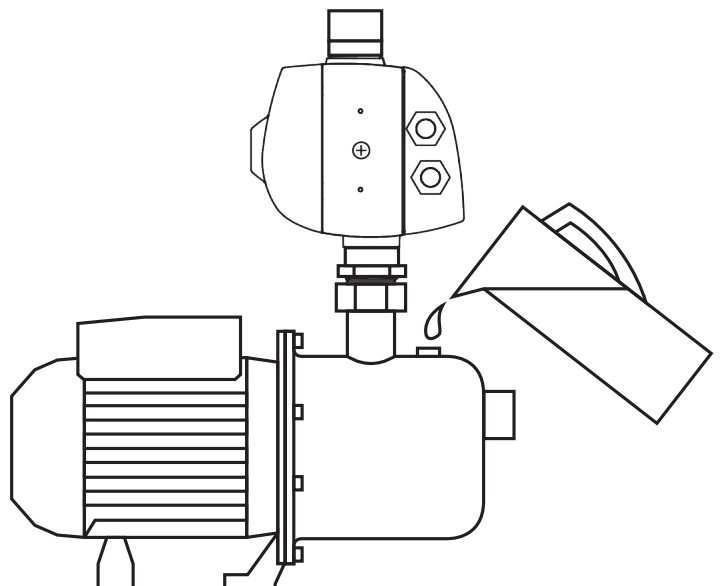





### INCORRECT INSTALLATION

**INCORRECT**  
THE PUMP IS CONNECTED INCORRECTLY. ALWAYS ENSURE WATER INLET AND OUTLET ARE CORRECT.

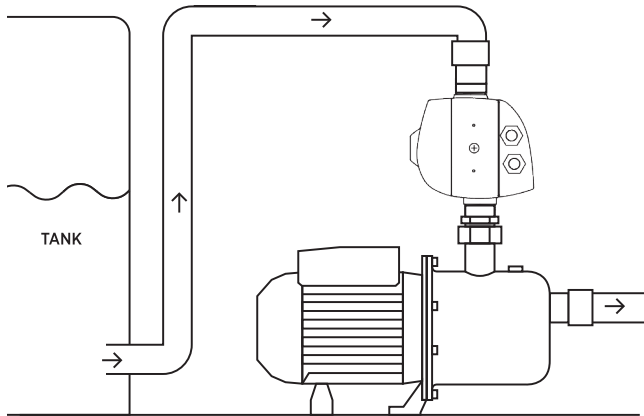

### INCORRECT INSTALLATION

**INCORRECT**  
PUMP IS NOT INSTALLED ON A LEVEL SURFACE. ALWAYS ENSURE THE PUMP IS INSTALLED LEVEL

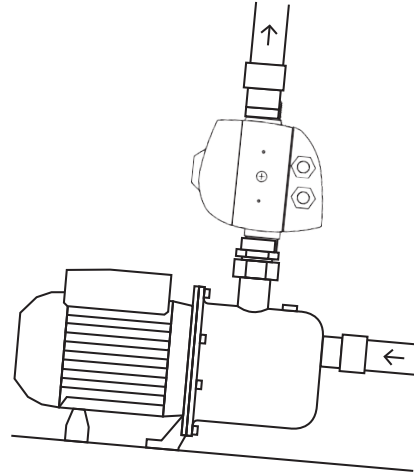

### INCORRECT INSTALLATION

**INCORRECT**  
DON'T USE EXTENSION LEADS

NEVER USE AN EXTENSION CABLE TO CONNECT THE PUMP TO MAINS POWER

ALWAYS CONNECT THE PUMP DIRECTLY TO THE DEDICATED POWER OUTLET

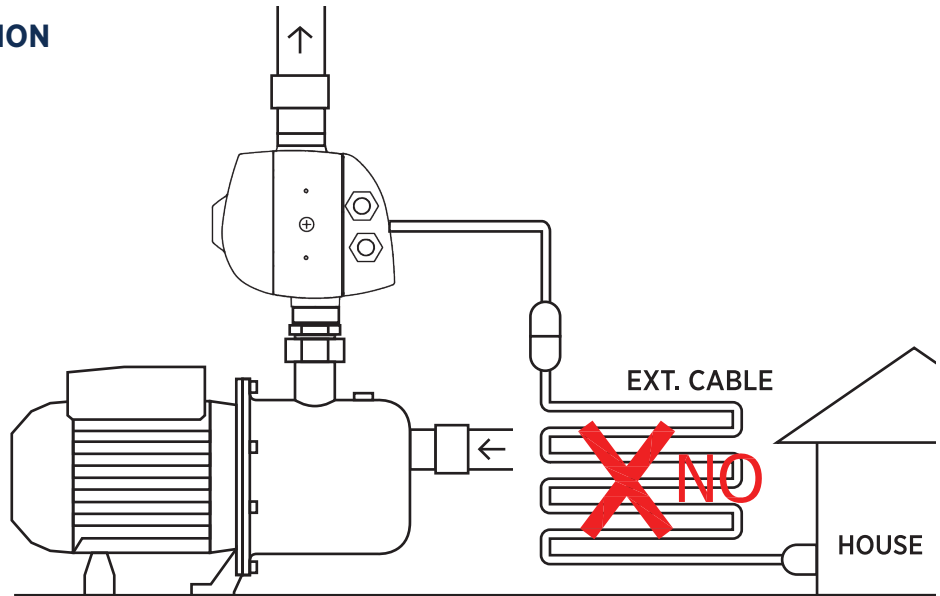

### INCORRECT INSTALLATION

**IMPORTANT**  
RAIN-MAINS SYSTEMS MUST NOT BE USED FOR USE WITH SUCTION LIFT, UNLESS A PUMP SHUT-OFF CONTROLLER IS ADDED

FOR INSTALLATIONS WHERE THE PUMP IS ABOVE THE OUTLET OF THE TANK, ALWAYS USE A FOOT VALVE IN THE TANK, OR A SWING-CEHCK VALVE IF VIABLE

**INCORRECT**  
NO FOOT VALVE

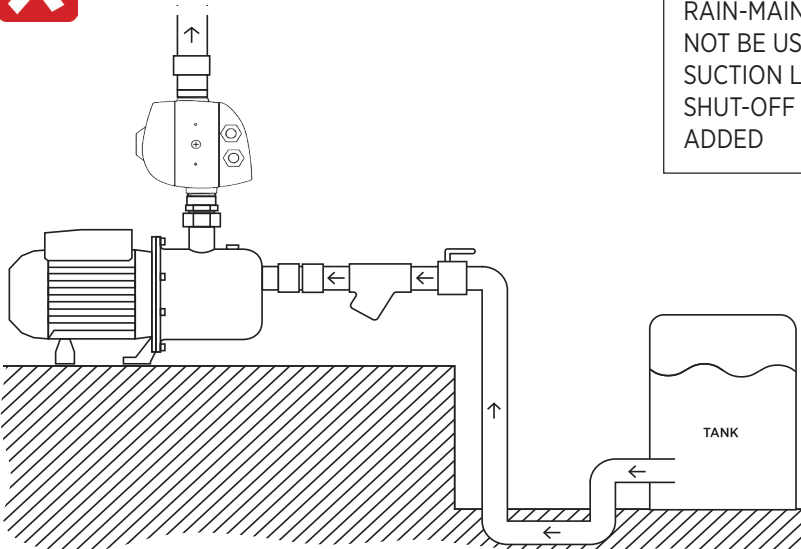



## INCORRECT INSTALLATION

### IMPORTANT: PIPES TOO SMALL

FOR PUMP INLET, USE 25MM PIPE (INTERNAL DIAMETER.) WE RECOMMEND 30MM FOR BEST PERFORMANCE. (FOR PUMPS WITH 32MM INTAKE OR LARGER, USE SUCTION PIPE ONE OR MORE SIZE LARGER.)

FOR THE OUTLET (DISCHARGE) PIPEWORK, USE PIPE THAT IS THE SAME DIAMETER AS THE OUTLET OF THE PUMP, OR NO MORE THAN ONE SIZE SMALLER.

BIGGER PIPE = BETTER PERFORMANCE

### PLEASE READ INSTRUCTIONS FOR MORE DETAILED INSTALL INFORMATION

### IMPORTANT

FOR VERY LONG SUCTION/INTAKE PIPEWORK, IT IS CRITICAL THAT THE CORRECT PIPE SIZE IS USED ESPECIALLY IN SUCTION-LIFT APPLICATIONS, CHECK WITH A QUALIFIED PUMP TECHNICIAN FOR THIS TYPE OF INSTALLATION

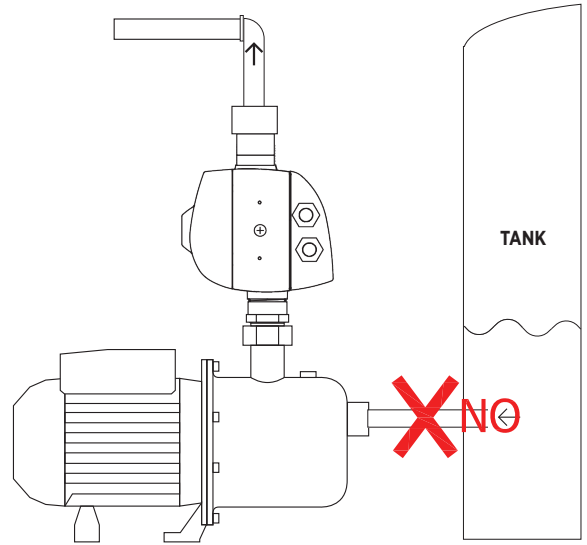

## INCORRECT INSTALLATION

**INCORRECT**  
PUMP IS INSTALLED WITHOUT BARREL UNION'S, A Y-STRAINER & A BALL VALVE

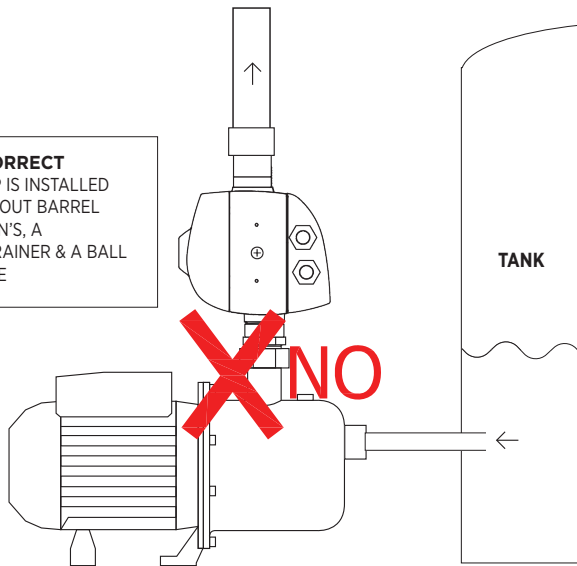

## INCORRECT INSTALLATION

**INCORRECT**  
PUMP IS INSTALLED WITHOUT A CHECK VALVE OR A FOOT VALVE

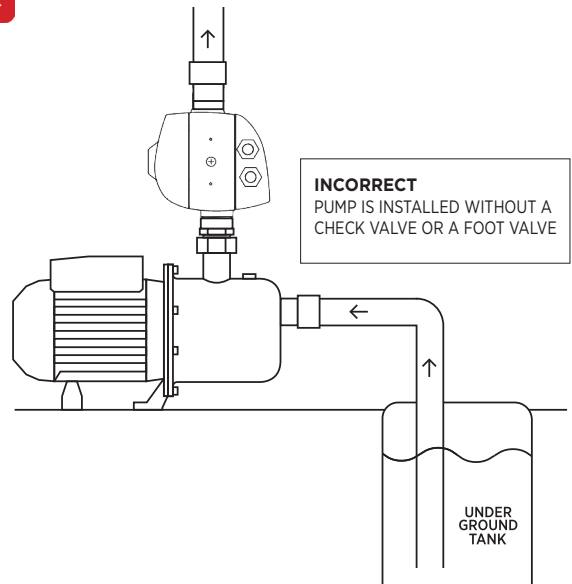

## DANGER

### DANGER

ALWAYS DISCONNECT THE PUMP FROM POWER WHEN INSTALLING, AND WHILE SERVICING OR REPAIRING.

### DANGER

ENSURE THE PUMP IS CONNECTED TO A POWER OUTLET THAT IS PROTECTED BY A SAFETY SWITCH (RCD.) IT IS THE BEST PRACTICE TO HAVE A DEDICATED CIRCUIT

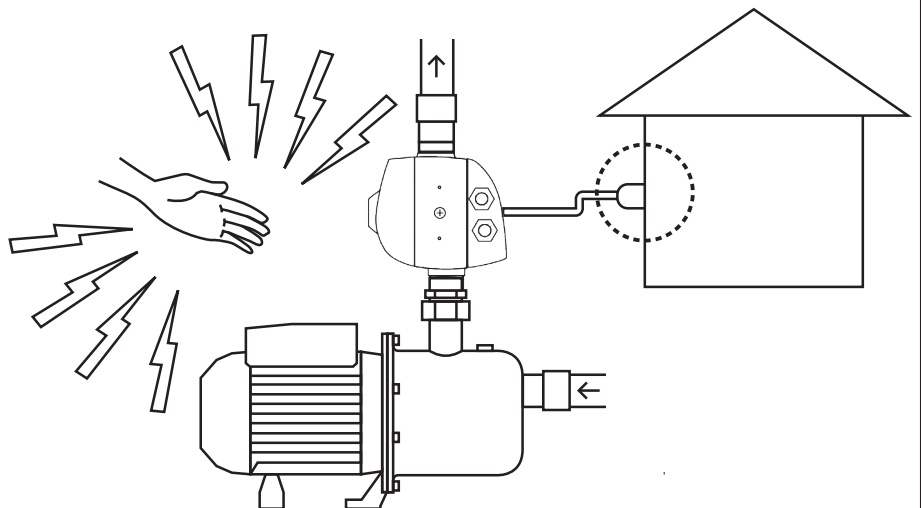

**IMPORTANT**

CONSIDER NEIGHBOURS WHEN INSTALLING THE PUMP. ALL PUMPS MAKE SOME NOISE.

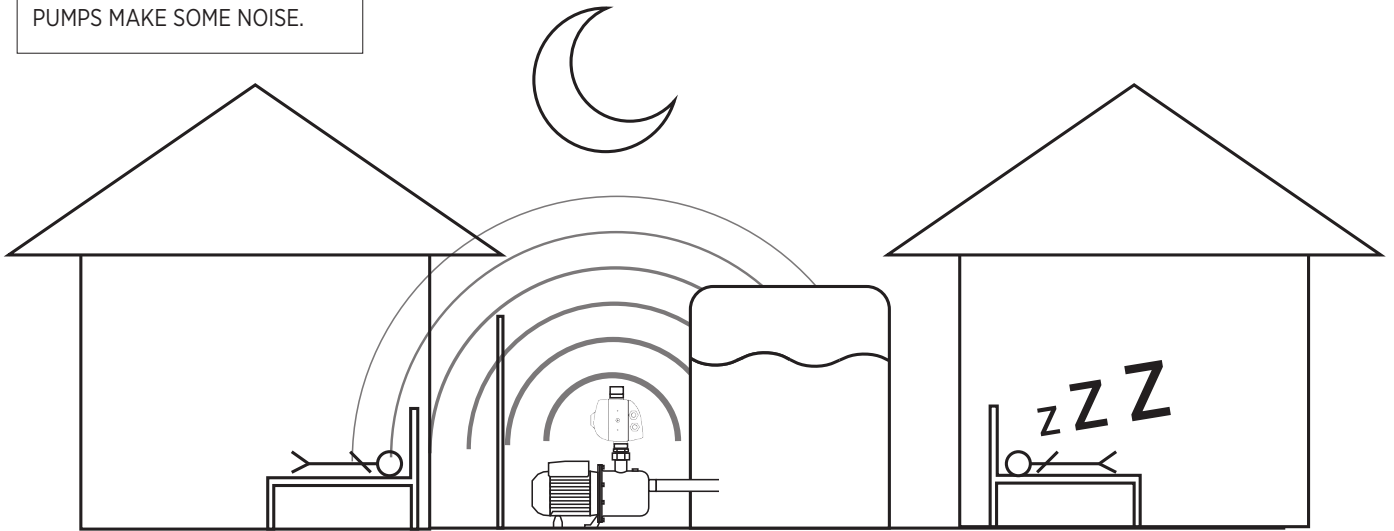

**CORRECT INSTALLATION: WITH COVER**

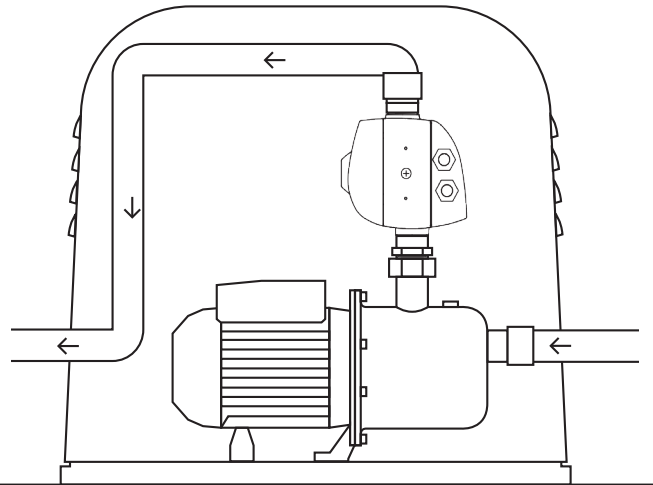

**INCORRECT INSTALLATION**

**IMPORTANT**

DO NOT EXPOSE THE PUMP DIRECTLY TO THE ELEMENTS. WE RECOMMEND THE PUMP IS PROTECTED WITH A PUMP COVER

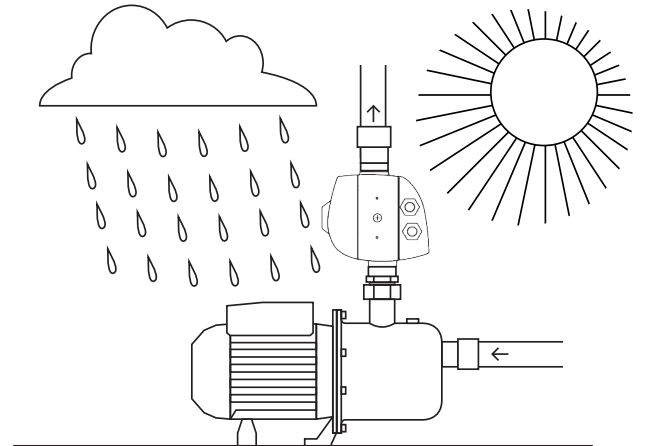

**IMPORTANT**

ENSURE THE PUMP SIZED CORRECTLY FOR THE JOB. TOO SMALL = LOW PERFORMANCE AND MAY USE EXCESS POWER, AND/OR OVER HEAT MOTOR AND/OR CAUSE PREMATURE FAILURE. THIS IS NOT A WARRANTY FAULT IF THIS OCCURS.

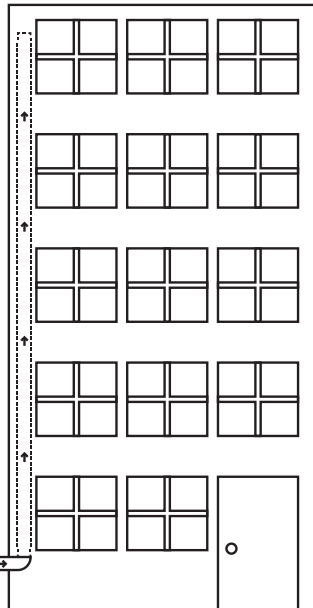

**X NO**

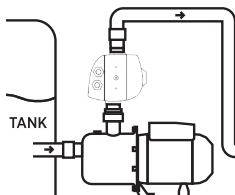

**PIPEWORK MUST ALIGN WITH THE PUMP**

STRESS ON THE PUMP DUE TO THE PIPEWORK BEING CROOKED WILL LEAD TO FAILURE OF THE PUMP THAT IS NOT COVERED BY WARRANTY.

