



EXTERNAL
RAIN MAINS SYSTEM

TECHNICAL DATA

MODEL: RM4000-5

PUMP: PRESSURE PUMP WITH RM1500-2 VALVE

CHARACTERISTIC CURVE & PERFORMANCE DATA

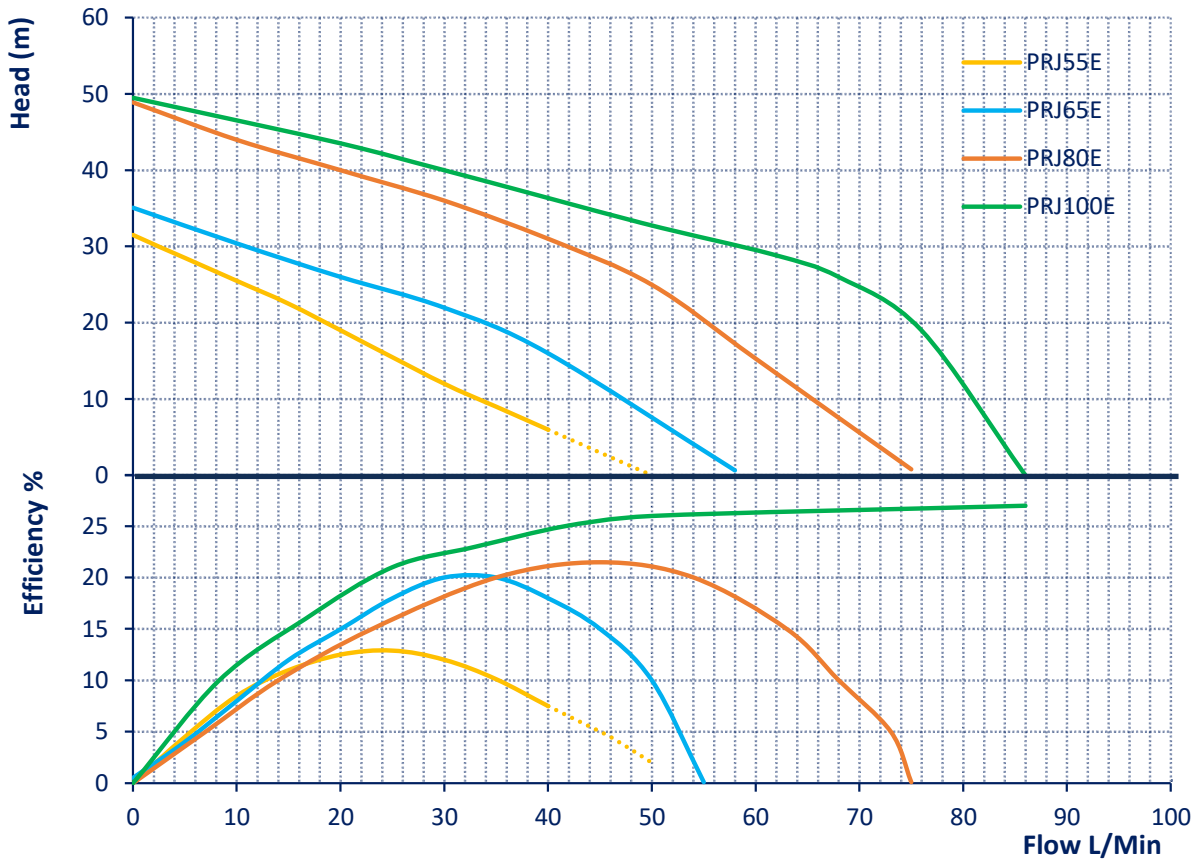

TYPE	Nominal Power (P2)		Input Power (P1)	Capacitor	Input Current
	W	HP			
Single Phase	W	HP	W	μF	240V
PRJ55E	500	0.7	510	10	2.2A
PRJ65E	440	0.6	600	12.5	2.4A
PRJ80E	740	1	990	16	4.5A
PRJ100E	970	1.2	1150	25	5.7A

TYPE	L/MIN	0	20	40	60	80
PRJ55E	HEAD (M)	31.5	19	6	-	-
PRJ65E		35.1	26	16	-	-
PRJ80E		48.9	40	31	15.3	0
PRJ100E		50	43	37	30	10

DIMENSIONS & WEIGHT

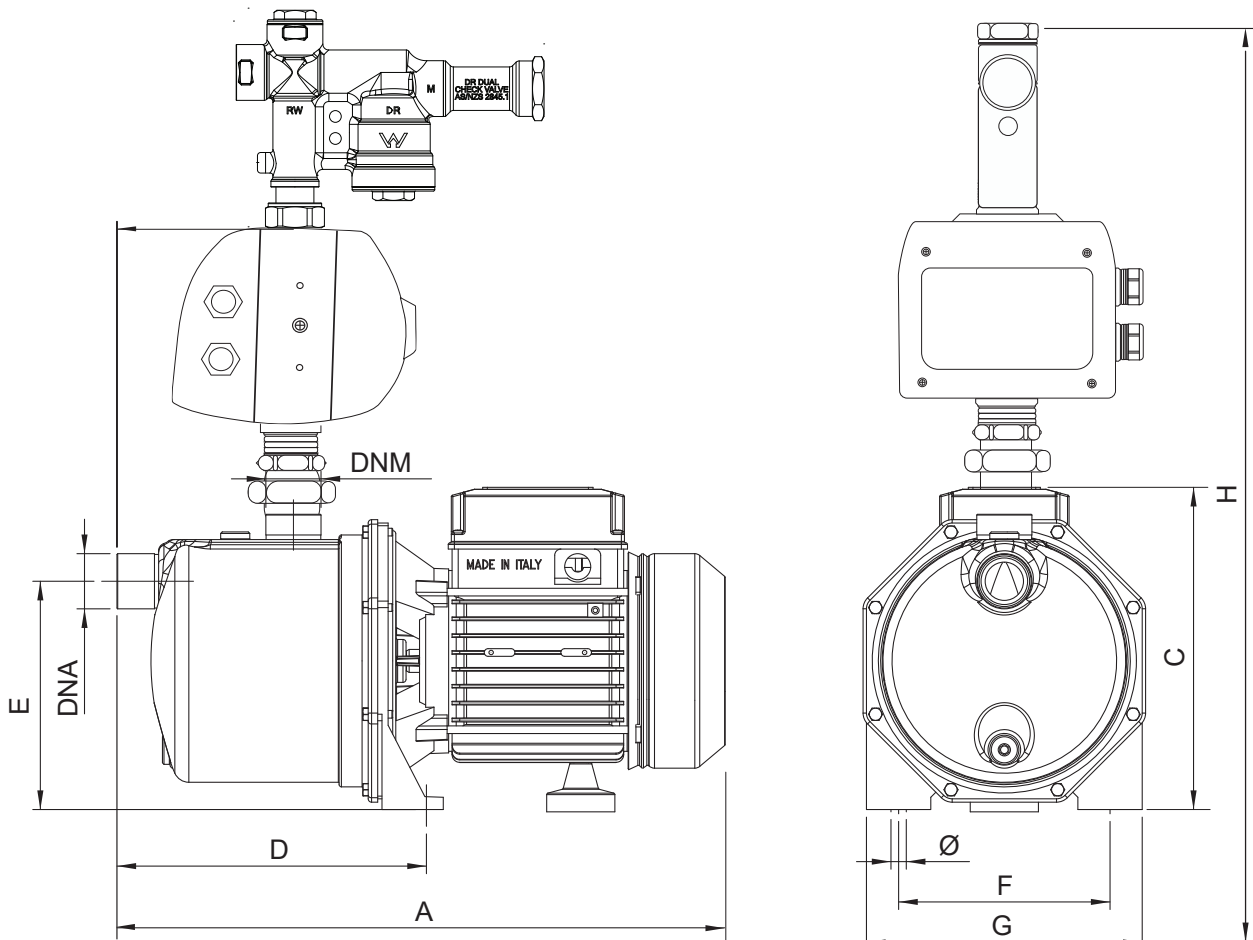

EXTERNAL RM4000-5 SYSTEM

MODEL	DIMENSIONS (MM)										PACKING (MM)			WEIGHT (KG)
	A	B	C	D	E	F	G	H	DNA	DNM	L	W	H	
PRJ55E	320	70	200	160	135	130	180	480	1"	1"	250	190	500	6.9
PRJ65E	380	105	200	206	150	140	180	520	1"	1"	400	200	550	9.1
PRJ80E	400	105	96	215	150	96	206	530	1"	1"	440	190	550	11.3
PRJ100E	420	122	95	210	150	150	225	530	1"	1"	250	190	550	17.7