



PUMPS AUSTRALIA

BETTER • FASTER • EASIER



VARIABLE
SPEED DRIVE
WALL MOUNT

TECHNICAL DATA

MODEL: VSC1-10W | VSC1-12W | VSC3-9W | VSC3-14W
CODE: 21297 | 21910 | 21934 | 21941

CONTROL PANEL GUIDE

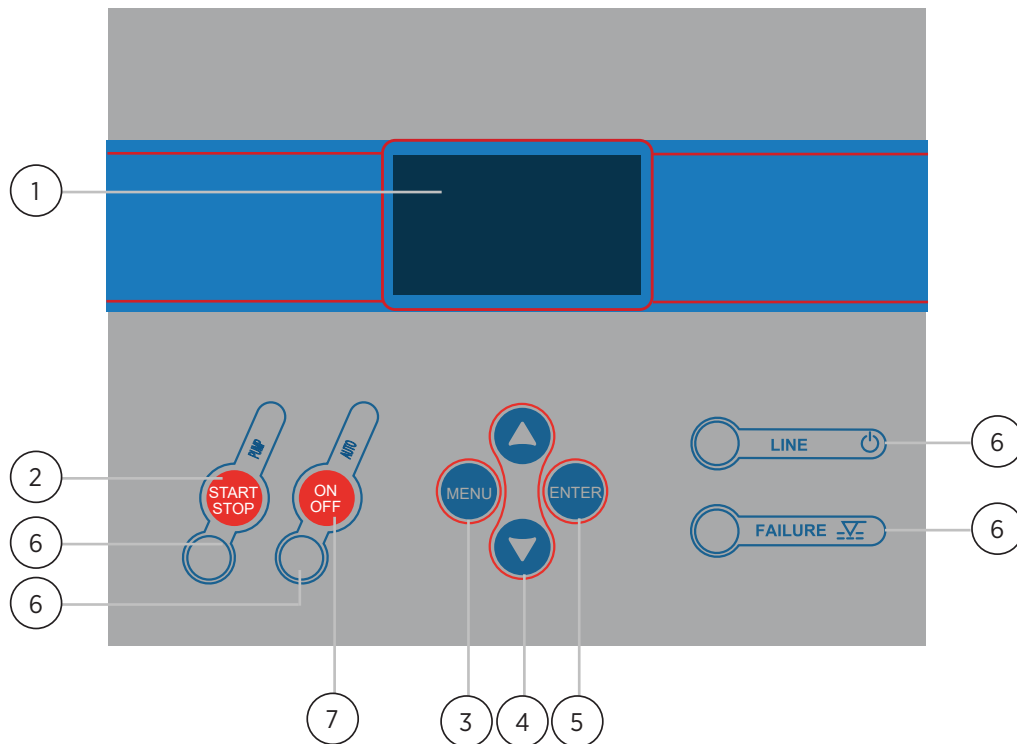

VARIABLE SPEED DRIVE

POSITION CONTROL

- 1 LCD Screen. Shows the pressure in working mode
- 2 MANUAL START-STOP pushbutton
- 3 Pushbutton for ENTER or EXIT menu.
- 4 With these pushbuttons we can change programming values showed in the LCD screen (1)
- 5 ENTER for saving programmed values. Every pulsation is succeeded by a new field of the CONFIGURATION MENU. Whenever we want to quit the configuration sequence press MENU (3) accepting the changes.
- 6 Led lights:

 LINE green: Electric supply. ON when it is connected.

 FAILURE red: Bright or intermittent depending on type of failure.

 PUMP yellow: When it is bright means pump working. It is lit with the pump stopped or when the device is not connected.

 AUTOMATIC green: it is bright in AUTOMATIC mode. When it is intermittent in MASTER&SLAVE mode it means that this device will be auxiliary in the following cycle.
- 7 ON/OFF: It allows to change from AUTOMATIC to MANUAL mode or vice versa.

DIMENSIONS & WEIGHT

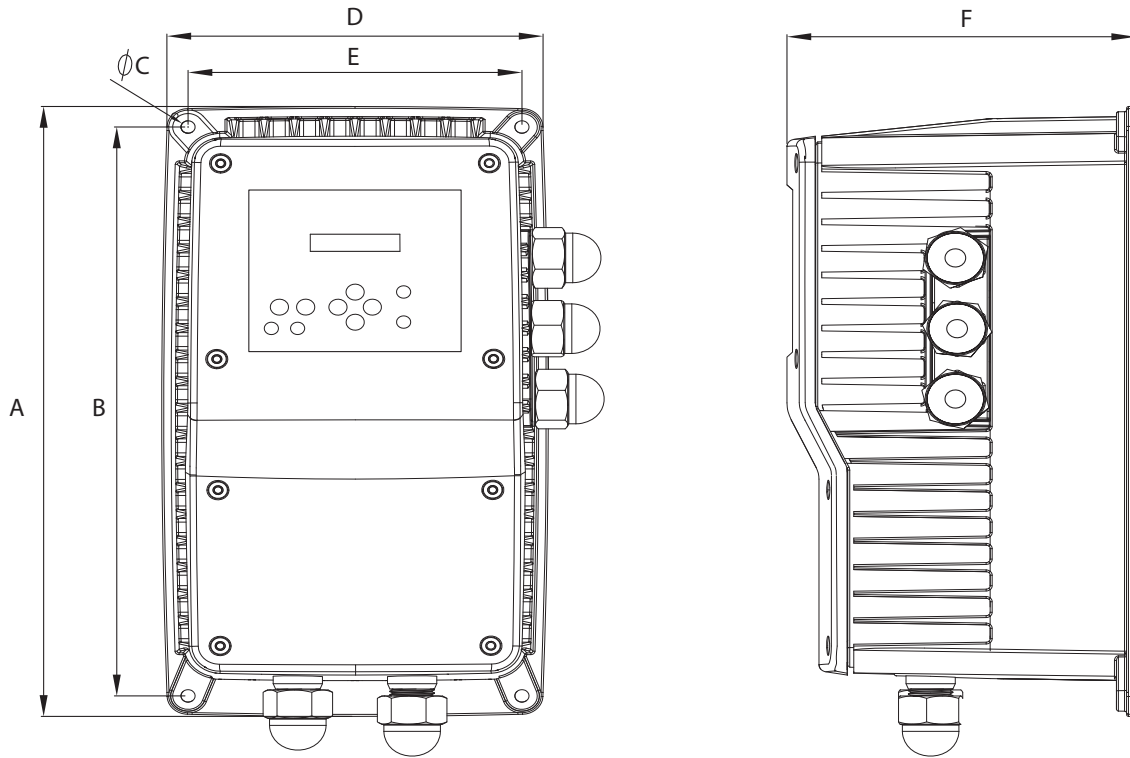

VARIABLE SPEED DRIVE

MODEL	DIMENSIONS (MM)						PACKING (MM)			WEIGHT (KG)
	A	B	CØ	D	E	F	L	W	H	
VSC Wall Mount	344	321	7	186	165	173	190	176	350	5