



## DRAINAGE PUMPS

### INSTRUCTION MANUAL

**MODEL:** RDP SERIES

**CODE:** 7457 | 22030 | 7464 | 7471 | 7679 | 7686 | 7693

# CONTENTS

<b>Prior to Installation and Operation   Product Specifications</b>	3
<b>Preparing for Installation   Checks to Make Before Installation</b>	4
<b>Electrical Wiring   Earthing</b>	5
<b>Connecting the Power Supply   Power Cable</b>	6
<b>Electrical Circuit Diagrams   Checking of Direction of Rotation   Operation</b>	7
<b>Test Operation   Operation</b>	8
<b>Operating Water Level   Motor Protection System   Ventilation of Pump Pits   Maintenance and Inspection</b>	9
<b>Prior to Inspection</b>	10
<b>Storage   Oil Inspection and Change</b>	11
<b>Troubleshooting</b>	12
<b>Warnings &amp; Important Information</b>	14
<b>Warranty Record   Installation Checklist</b>	15

## INSTRUCTION MANUAL & INSTALLATION GUIDE

### PRIOR TO INSTALLATION AND OPERATION

The Installer must consult a WHS supervisor and operate in a safe manner, and ensure the installation complies with all relevant plumbing and electrical regulations. The installer should also consult an engineer for site assessment and correct installation methods.

When using these pumps with guide rails, the base must be removed.

When the pump is delivered, first perform the following checks.

#### INSPECTION

While unpacking, inspect the product for damage during shipment, and make sure all the fasteners, clamps, etc. are tightened properly.

#### SPECIFICATION CHECK

Check the model number to make sure it is the product that was ordered. Be certain it is the correct voltage and frequency.

### PRODUCT SPECIFICATIONS

#### CAUTION

- Do not operate this product under any conditions other than those for which it is specified.
- Failure to observe this precaution can lead to electrical shock, electrical leakage, fire, water leakage, damage to property, injury and death.

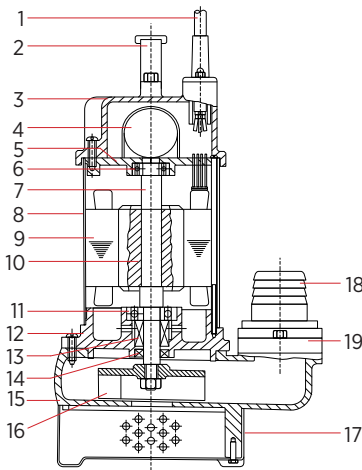

For specific exploded view scan this code and search for the model number on our website.



#### TYPICAL PARTS BREAK UP, DESIGNS WILL DIFFER

No.	Name	Material
1	Cable	H07RNF
2	Handle	Plastic
3	Upper Cover	Cast Iron
4	Capacitor (IPH)	
5	Bearing Shelf	Cast Iron
6	Bearing	
7	Shaft	S/S Gr 410
8	Motor Frame	S/S Gr 304
9	Stator	
10	Rotor	
11	Bearing	
12	Bearing Bracket	Cast Iron
13	Mechanical Seal	
14	Oil Seal	
15	Pump Housing	Cast Iron
16	Impeller	Cast Iron
17	Strainer	S/S Gr 304
18	Discharge Outlet	Plastic
19	Discharge Flange	Plastic

## CAUTION

- Do not use pump in liquids other than water, stormwater, or treated wastewater free of solids. Do not use pump in oil, salt water, flammable liquids, organic solvents, or any other chemical. Do not use in food processing.
- Use with a power supply voltage within  $\pm 5\%$  of the rated voltage.
- Do not use in water temperatures outside the range of 0-35°C. This can lead to failure, electrical leakage, shock or fire.
- Do not use in the vicinity of explosive or flammable materials, or areas classified as hazardous.
- Use only in fully assembled state.

**NOTE:** Consult your dealer or representative before using with any liquids others than those indicated in this document.

## **\*\*DANGER!!\*\***

**Do not conduct electrical work unless you are a licensed Electrician.**

## PREPARING FOR INSTALLATION

Before Installing the pump at a work site, you will need to have the following tools and instruments ready.

- Insulation resistance tester
- AC Voltmeter
- AC ammeter (clamp on type)
- Bolt and nut tighteners
- Power supply connection tools
- Ensure adequate power supply is available

**NOTE:** Please read also the instructions that come with each of the test instruments.

## CHECKS TO MAKE BEFORE INSTALLATION

### When a three pin plug is used:

Use the insulation tester to measure the insulation resistance between the active & neutral pins and earth pin. Insulation Resistance must be in accordance with the applicable Australian Standard.

### When pump is permanently connected:

The pump will need to be disconnected then use an insulation tester, measure the insulation resistance between the active & neutral cores and the earth core. (Green/Yellow).

Insulation Resistance must be in accordance with the applicable Australian Standard.

## WARNING

- When installing the pump, pay close attention to its centre of gravity and weight. If it is not lowered into place correctly, it may fall and be damaged or cause injury.
- When transporting the pump by hand, be sure to employ manpower commensurate with the weight of the pump. To avoid back injury when lifting the pump, bend the knees to pick it up rather than bending your back.

## CAUTION

- Do not under any circumstances install or move the pump by suspending it from the power cable. The cable may be damaged, causing electrical leakage, shock, fire, injury or death.
1. Attach the hose to the hose coupling as far as it will go, then fasten it securely with the hose band. If using hose, attach the hose to the hose coupling as far as it will go, and fasten securely with hose-clamps or similar. If using rigid pipework ensure it is connected correctly.
  2. Avoid dropping the pump or other strong impact. Lift the pump by holding it firmly with both hands or by attaching a rope or chain to the handle, use mechanical assistance to lower the pump into place to avoid injury and damage.

3. Install the pump in an upright position on a secure base. Ensure that the inlet to the pump is not blocked by sludge, mud, solids, plastic bags, rubbish.
4. Where a float switch is attached to the pump, ensure the float switch is free to operate without interfering with tank walls, pipe work etc.
5. A swing check non-return valve and isolating valve should be fitted to discharge pipe close to the pump but accessible so that it can be replaced.
6. The pump must not be used in or at swimming pools, garden ponds or any body of water where people may enter the water.

 **CAUTION**

- Avoid dry operation, which will not only lower performance but can cause the pump to malfunction, leading to electrical leakage and shock.
7. Install the pump in a location with sufficient water level, where water collects readily.

**NOTE:** Please refer to “Operating Water Level” (page 10) for the water level necessary for operation.

**NOTE:** The discharge end should be located higher than the water surface. If the end of the hose or pipe is submerged, water may flow back to the pump when the pump is stopped; and if the hose end is lower than the water surface, water may overflow when the pump is turned off.

 **CAUTION**

- If large quantities of earth are sucked up, damage resulting from erosion in the pump will lead to premature wear and failure of the pump, and potential electrical leakage and shock.

## ELECTRICAL WIRING

### PERFORMING ELECTRICAL WIRING

 **CAUTION**

- Electrical Wiring should be performed by a qualified/licenced person in accord with all applicable regulations. Failure to observe this precaution not only risks breaking the law but is extremely dangerous.
- Incorrect wiring can lead to electrical leakage, electrical shock, fire, property damage, injury or death.
- Always make sure the pump is equipped with the specified overload protectors and fuses or breakers, as required by law, so as to prevent electrical shock from an electrical leak or pump malfunction.
- The voltage, frequency and current rating are displayed on the name plate, please ensure that the power supply meets the requirements.

8. To prevent the pump strainer stand from becoming submerged in mud, causing it to suck in debris, mount it on a block or firm base.

## EARTHING

 **WARNING**

- Do not use the pump without first earthing it properly. Failure to earth it can lead to electrical shock from an electrical leak or pump malfunction.

 **CAUTION**

- Do not attach the earth wire to a gas pipe, water pipe, lightning arrestor or telephone earth wire. Improper earthing can result in electrical shock.

## CONNECTING THE POWER SUPPLY

### WARNING

- Before connecting leads to the terminal, make certain the power supply is turned off (circuit breaker, etc), to avoid electrical shock, shorting, or unexpected starting of the pump, leading to injury or death.

### WARNING

- Before inserting the power supply plug make certain the power supply is turned off (circuit breaker etc), to avoid electrical shock, shorting, or unexpected starting of the pump, leading to injury or death.

### CAUTION

- Do not use the pump with the power cable or plug connected loosely, which can result in electric shock, shorting, fire, injury or death

### CAUTION

- Draw power from a dedicated power outlet. Sharing the outlet with other equipment may overheat the branch outlet and could result in a fire.
- For pumps less than 10 amps, it is strongly recommended to have them connected to a dedicated circuit without any other appliances connected, to reduce the risk of over current draw which will lead to the circuit breaker tripping, when the pump should be operating. Note that this circumstance is not a failure of the pump and is certainly not covered by warranty. In extreme circumstances, sharing the outlet with other equipment may overheat the power outlet and/or cabling and could result in a fire.
  - Ensure the amperage supply matches the pump, over 10A the pump must be supplied from a dedicated 15A power outlet.
  - Ensure all wiring is connected according to applicable wiring rules and regulations.

### CAUTION

- Be sure to use a dedicated power supply with a ground/earth leakage circuit breaker.

## POWER CABLE

### CAUTION

- If it is necessary to extend the power cable, this MUST be completed by a licenced electrician, and a written record must be kept, signed by the electrician, certifying that the extension is safe and water tight and weatherproof. Use a core size equal to or larger than the original. This is necessary not only for avoiding a voltage drop, but to prevent cable overheating which can result in fire, electrical leakage, electrical shock, injury and death. Refer to AS3000
- If a cable with cut insulation or other damage is submerged in the water, there is a danger of water seeping into the motor causing a short. This may result in damage to pump, electrical leakage, electrical shock fire, injury or death.
- Be careful not to let the power cable be cut or become twisted. This may result in damage to the pump, electrical leakage, electrical shock, fire, injury or death.
- If necessary to submerge connection leads of the power cable in water, first seal the leads completely in a molded sleeve, to prevent electrical leakage, electrical shock, fire, injury or death. All connections must be in accordance with the applicable Australian Standards and completed by a Licenced Electrician.
- Do not allow power connection to become wet.
- Make sure that the cable does not become excessively bent or twisted, and does not rub against a structure in a way that might damage it.

## ELECTRICAL CIRCUIT DIAGRAMS

### SINGLE PHASE BELOW 1HP (INCLUDE 1HP)

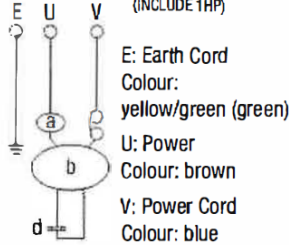

### SINGLE PHASE ABOVE 1HP

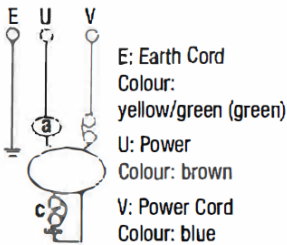

### THREE PHASE

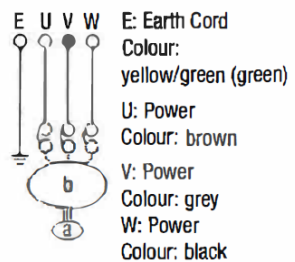

- THREE PHASE PUMPS must be connected to a external motor starter fitted with a contactor and overload. The nominal current of the motor starter must correspond to the electrical data marked on the pump nameplate.

## CHECKING OF DIRECTION OF ROTATION (THREE PUMPS PHASE ONLY)

The direction of rotation should be checked every time the pump is connected to a new installation. Check the direction of rotation as follows:

**DANGER!!!** At all times keep fingers and hands away from impeller.

1. Position the pump so that the impeller can be observed.
2. Start the pump momentarily, pump will jerk - be careful.
3. Observe the rotation of the impeller.

The correct direction of the rotation is indicated by an arrow on the top of the motor (anticlockwise when seen from the bottom). If the impeller rotates in the wrong direction, reverse the direction of rotation by interchanging two phases of the motor.

If the pump is connected to a piping system, the direction of rotation can be checked as follows:

1. Start the pump and check the quantity of water or the discharge pressure.
2. Stop the pump and interchange two of the phases to the motor.
3. Start the pump and check the quantity of water or the discharge pressure.
4. Stop the pump.
5. Compare the results taken under point 1 and 3. The connection which gives the larger quantity of water or the higher pressure is the correct direction of rotation.

## OPERATION

### BEFORE STARTING

1. Make sure once again that the product is of the correct voltage and frequency rating.

### CAUTION

- Using the product with a voltage and frequency other than the rated voltage frequency will not only lower its performance but damage the product.

NOTE: Confirm the rated voltage and frequency on the model name plate.

2. Confirm the wiring, supply voltage, circuit breaker capacity, and motor insulation resistance.

Reference insulation resistance: 20MΩ or greater.

**NOTE:** The reference insulation resistance (20MΩ or greater) is the value when the pump is new or has been repaired.

3. The setting on the circuit breaker or other overload protector should be made in accord with the rated current of the pump.

**NOTE:** See the model name plate on the pump for its rated current.

## TEST OPERATION

### CAUTION

- Never operate the pump while it is suspended in the air. The recoil will result in injury, property damage or death
1. Run the pump for a short time (3-10 minutes) and confirm the following:
    - Using a clamp meter, measure the operating current on all actives and/or neutral conductors.

If the operating current exceeds the rated value, pump motor overload may be a cause, or there is too much back pressure. Make sure the pump has been installed under proper conditions as described in Installation (page 5).

- Using an AC voltmeter (tester), measure voltage at the terminals.

*Supply voltage tolerance: within  $\pm 5\%$  of rated voltage.*

If the supply voltage is outside the tolerance, possible causes are the power supply capacity or an inadequate extension cable. Look again at Electrical Wiring (page 8)

### CAUTION

- In case of very excessive vibration, unusual noise or odour, turn off the power immediately and consult with your nearest dealer or representative. Continuing to operate the pump under abnormal conditions may result in electrical shock, fire, property damage, injury or death.
2. If the test operation reveals no problems, continue operating the pump.

## OPERATION

### WARNING

- Do not operate the pump in dry pit, well, trench etc.
- The pump may become very hot during operation. To avoid being burned, be careful not to contact the pump accidentally.
- Make sure no extraneous objects such as pins, nails or other metal objects, cloth, wipes, rocks, wood, napkins or sanitary items or products of this nature are sucked into the pump. These can damage the pump or cause it to malfunction, and can result in electrical shock or electrical leakage.
- In case of a power outage, turn off the power to the pump to avoid having it start unexpectedly when the power is restored, presenting serious danger to people in the vicinity.
- Pay careful attention to the water level while the pump is operating. Dry operation may cause the pump to malfunction.

**NOTE:** See “Operating water level” for the water level necessary for operation.

- Sharp bends in the hose, especially near its base, may cause air pockets to form resulting in idle operation. Lessen the degree of bending while continuing to operate the pump.



## OPERATING WATER LEVEL

### ⚠ CAUTION

- Do not operate the pump below the C.W.L. (continuous running water level). Failure to observe this condition may result in damage to pump, through it overheating, leading to electrical hazards.



## MOTOR PROTECTION SYSTEM (THERMAL CUT-OUT)

Some single phase pumps have a built-in motor protection system (Thermal Cut-Out). If an excessive current is detected or the motor overheats, for reasons such as the following, the pump will automatically, stop operating regardless of the water level, to protect the motor.

- Change in supply voltage polarity
- Overload
- Open-phase operation or operation under constraint

**NOTE:** Always determine the cause of the problem and resolve it before resuming operation. Simply repeating cycles of stopping and restarting will result in damage to the pump. Do not continue operation at a very low lift, low water level, or while the strainer stand is clogged with debris. Not only will performance suffer but such conditions may cause noise, heavy vibration, and malfunctioning.

## VENTILATION OF PUMP PITS

Ensure that adequate ventilation is installed, if required, and is in full accordance with all applicable plumbing regulations. NEVER enter a pump well / pump sump / pump pit, or similar confined space, without adequate ventilation and recovery equipment, in accordance with all Australian WHS rules and regulations and confined space guidelines. Compliance with this instruction is the installers responsibility as we have no control over the installation.

## MAINTENANCE AND INSPECTION

Regular maintenance and inspections are necessary for continued efficient functioning of the pump. If any abnormal conditions are noticed, refer to the section on Troubleshooting (pages 12-13) and take corrective measures immediately.

It is highly recommended that a spare pump be kept ready in case of any problems.

## PRIOR TO INSPECTION

### WARNING

- Consult WHS supervisor for correct procedures.

### WARNING

- Detach the power cable from the receptacle or terminals, after making certain the power supply (circuit breaker, etc) is turned off. Failure to follow this precaution will result in a serious accident or death from electrical shock or unexpected starting of the pump motor.
1. Washing the Pump: Remove accumulated matter from the surface of the pump and wash it with clean water. Take special care to remove any debris from the impeller.
  2. When inspecting the pump exterior look for any peeling or chipped paint, and make sure the nuts and bolts are fastened tightly. Any cracks in the surface should be repaired by cleaning up that area, drying it and then applying touch-up coating.

**NOTE:** touch-up is not supplied. Note that some kinds of damage or looseness may require that the unit be dismantled for repairs. Please consult with your nearest dealer.

FREQUENCY	INSPECTION ITEMS
<b>MONTHLY</b>	<p>Measure insulation resistance - Reference resistance 20MOhms or greater</p> <p><b>NOTE:</b> if the insulation resistance has become notably lower than previous inspection, an inspection of the motor will be necessary.</p> <ul style="list-style-type: none"> <li>• Measure operating current - Compare with rated current.</li> <li>• Measure supply voltage - Compare with allowable range (within <math>\pm 5\%</math> of rated voltage)</li> <li>• Pump inspection.</li> <li>• A noticeable drop in performance may indicate wear in the impeller, etc., or else clogging of the strainer stand, etc. Remove clogged debris, and replace any worn parts.</li> </ul>
<b>BI-ANNUALLY</b>	<ul style="list-style-type: none"> <li>• Oil inspection.</li> <li>• Check the oil every six months or after 1,000 hours of use, whichever comes first.</li> </ul>
<b>ANNUALLY</b>	<ul style="list-style-type: none"> <li>• Change Oil.</li> <li>• Change oil every 12 months or after 2,000 hours of use, whichever comes first.</li> <li>• Designated Oil: Turbine oil VG32 - Caltex- or similar.</li> <li>• Change mechanical seal.</li> </ul> <p><b>NOTE:</b> Trained personnel are required for inspecting and replacing the mechanical seal. Consult with your nearest dealer or representative.</p>
<b>2 TO 5 YEARS</b>	<ul style="list-style-type: none"> <li>• Overhaul - This should be carried out even if there are no problems with the pump. The frequency depends on how continuously the pump is in use.</li> </ul> <p><b>NOTE:</b> Consult with your nearest dealer</p>

## STORAGE

When the pump is out of use for an extended period, wash it and dry it thoroughly, then store it indoors.

**NOTE:** Always run a test operation before putting the pump back into service.

When the pump is left installed in the water, it should be run at regular intervals (about once a week).

## OIL INSPECTION AND CHANGE

- Inspecting Oil

Remove the Oil Plug (Hex. Bolt) and tilt the pump to drain a small amount of oil. If the oil is milk white or has water mixed with it, the Mechanical seal maybe faulty. In this case the pump will need to be dismantled and repaired.

- Replacing the Oil

Remove the Oil Plug and drain all the oil, then replace it with the specified amount.

**NOTE:** Used oil and other waste products should be disposed of by a qualified agent in accord with applicable laws. The Oil Plug packing and O-Ring should be replaced each time the oil is inspected or changed.

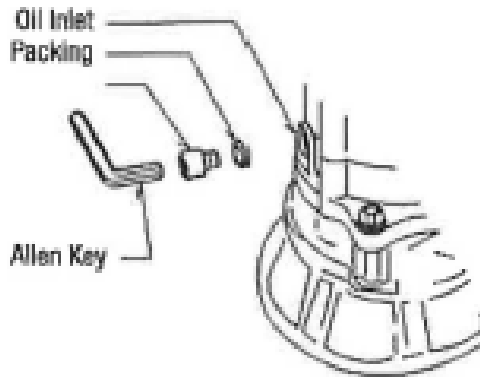

## TROUBLESHOOTING

**DANGER!!!** Always disconnect from power before working on the pump. Pump repairs must be carried out by a qualified technician.

TROUBLE	CAUSE	REMEDY
<b>Does not start. Starts but immediately stops</b>	Power Failure	Contact electricity supplier and/or electrician to ascertain and correct what the cause is.
	Large discrepancy between power source and voltage	
	Significant drop in voltage	
	Motor phase malfunction	Have electrician inspect and correct what the cause is.
	Electrical fault or tripped circuit or safety switch	
	Faulty float switch (if fitted)	Repair or replace the float switch
	Water is not high enough to activate the float	Not a fault, no action required
	Float is stuck in the down position	Change the setup so the float is not staying down
	Foreign matter clogging pump	Remove foreign matter and correct the reason that it occurred.
	Motor burned out	Repair or replace
Motor bearing failure	Repair or replace	

**DANGER!!!** Always disconnect from power before working on the pump. Pump repairs must be carried out by a qualified technician.

<b>Operates, but stops after a while</b>	Prolonged dry operation has activated motor protector and caused the pump to stop	Check the cause and rectify why it occurred
	High liquid temperature has activated motor protector and caused the pump to stop	
<b>Does not pump. Inadequate volume</b>	Reverse rotation (3 Phase Pumps)	Have an electrician correct the wiring (operation 2, 3)
	Significant drop in voltage	Contact electricity supplier
	Discharge head is high	Replace with pump with the required performance
	Loss due to friction in too small pipe	Install correct pipe size
	Low operating water level causes air suction	Correct the float switch position, or lower the pump.
	Leaking from discharge piping	Inspect. Repair
	Clogging of discharge piping	Remove foreign matter and correct the reason that it occurred
	Foreign matter in suction inlet	Remove foreign matter and correct the reason that it occurred
	Foreign matter clogging pump	Disassemble and remove foreign matter and correct the reason that it occurred
Worn impeller	Replace impeller	

<b>Over current</b>	Varying current and voltage	Contact electricity supplier
	Significant voltage drop	Have electrician inspect and correct what the cause is.
	Motor phase malfunction	
	Reverse rotation (3 Phase Pumps)	Have an electrician correct the wiring (operation 2, 3)
	Foreign matter clogging pump	Disassemble and remove foreign matter and correct the reason that it occurred
<b>Pump vibrates; excessive operating noise</b>	Motor bearing is worn or damaged	Replace bearing
	Shut off valve closed too far	Open shut off (valve)
	Piping resonates	Improve pipe mounting
	Reverse rotation (3 Phase Pumps)	Have an electrician correct the wiring (operation 2, 3)

## WARNING

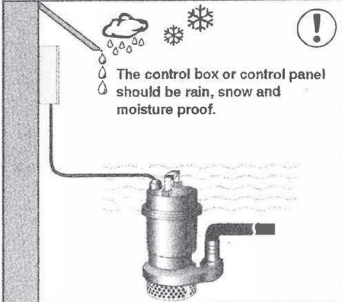

The control box or control panel should be rain, snow and moisture proof.

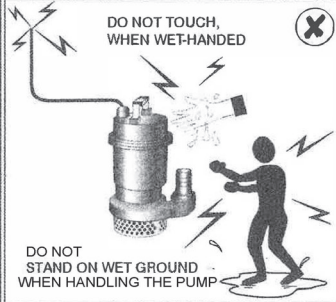

DO NOT TOUCH, WHEN WET-HANDED

DO NOT STAND ON WET GROUND WHEN HANDLING THE PUMP

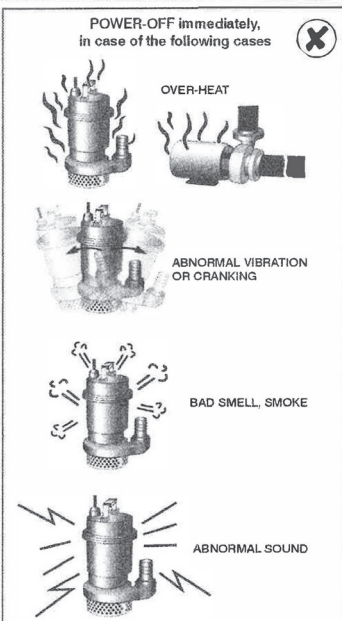

POWER-OFF immediately, in case of the following cases

OVER-HEAT

ABNORMAL VIBRATION OR CRANKING

BAD SMELL, SMOKE

ABNORMAL SOUND

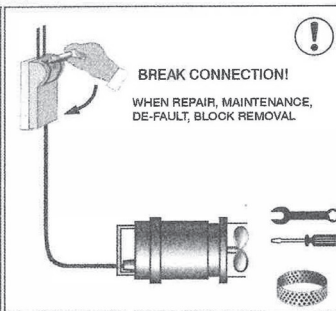

BREAK CONNECTION! WHEN REPAIR, MAINTENANCE, DE-FAULT, BLOCK REMOVAL

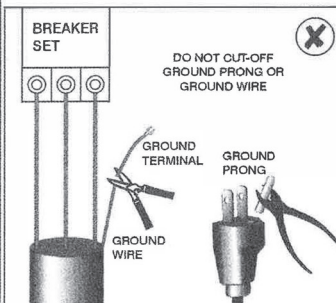

BREAKER SET

DO NOT CUT-OFF GROUND PRONG OR GROUND WIRE

GROUND TERMINAL

GROUND PRONG

GROUND WIRE

## WARNINGS & IMPORTANT INFORMATION

### **1. PIPE DETAILS**

- (a) **PIPE SIZE AND TYPE:** Install the pump as near as possible to the discharge to reduce the length of delivery pipe. Use as few bends as possible, every bend reduces performance.
- (b) **MORE INFO RE PIPE SIZE:** Ensure the pipe size is optimized for the Head (lift) and Flow and Velocity required. Pipes that are too small means more power will be used as the pump has to work harder to overcome the extra back-pressure from small pipes. A small short-term saving (in the cost of the pipes) will become a long-term liability.

### **2. SEAL JOINTS** Ensure all fittings and joints are watertight and airtight.

### **3. INSTALLATION AND ELECTRICAL WIRING** must adhere to state and local codes and must be completed before using the pump. All pumps come with an earth cable and all electrical installations must be earthed. Any Electrical work must be performed by a licenced Electrician. The installation must also comply with applicable Plumbing Regulations, it is the installers responsibility to ensure compliance.

### **4. IMPORTANT re SAFETY SWITCH (RCD)**

- (a) 240V Pumps must be connected to a suitable power circuit with an integral RCD (safety switch) having a rated residual operating current not exceeding 30mA, in the circuit breaker. Disconnect the pump from power supply when people are in the water, or when servicing or repairing the pump. All warranty is void if this instruction is not followed. Note: Plugging into existing outlets may cause low voltage supply to the motor, causing blown fuses, tripping of motor overload, or burnt out motor, which will not be covered by the Warranty.
- (b) 415V Pumps must be installed by a licenced Electrician, in compliance with the applicable Electrical Regulations & Australian Standards.

### **5. VOLTAGE** of power supply must match the voltage of the pump. Do not run on generator power from low quality/old generators. High quality "Sine-Wave" generators are usually acceptable but we cannot guarantee this, as we have no control over the generator that you use, it is your responsibility to ensure the generator used is fit for the purpose.

### **6. WARNING:** these pumps are not designed for, and must not be installed in locations classified as hazardous.

### **7. THE FOLLOWING MAY CAUSE SEVERE DAMAGE TO THE PUMP AND WILL VOID WARRANTY:**

- (a) Using an extension cord to power the pump.
- (b) Cutting the earth pin off the plug or using an adapter fitting or double adapter.
- (c) Working on the pump while connected to the power supply.
- (d) Removing motor housing, or disassembling the pump housing, except by a qualified technician
- (e) Pumping chemicals or corrosive liquids or flammable liquids.
- (f) Pumping hot liquids (Exceeding 35° Centigrade)
- (g) Using a generator for power supply - see 5
- (h) Operations that involve frequent starting. This will lead to premature failure of the capacitor.
- (i) Dry operation will destroy the pump seals and is not covered by warranty.

### **WARNING!!**

All installers must be a qualified Plumber or Pump Technician, and Electrical work must only be performed by a Licensed Electrician. Warranty is void if this is not followed.

### **WARNING!!!**

#### **ELECTRICAL PRECAUTIONS**

Before servicing a pump, always shut off the power supply and then make sure you are not standing in water and that there is no risk of electrical shock. If pump is direct-wired to the electrical circuit, have a qualified licensed electrician disconnect it before attempting any repairs or servicing.

**DO NOT ATTEMPT ELECTRICAL REPAIRS OF ANY SORT UNLESS YOU ARE A LICENSED ELECTRICIAN**

# WARRANTY RECORD- FILL IN AND RETAIN THIS WITH YOUR ORIGINAL PURCHASE RECEIPT

PURCHASER NAME .....  
PHONE NO .....DATE OF PURCHASE ..... / ..... / .....  
DEALER/STORE NAME .....  
DEALER SUBURB/TOWN .....  
PHONE NO .....BRAND & MODEL NUMBER OF PUMP .....  
BATCH NUMBER .....

Do NOT send this form to us, retain it for your record.

## **INSTALLATION CHECKLIST: MUST BE FILLED IN FOR WARRANTY TO APPLY**

Installer Name \_\_\_\_\_  
Qualification: \_\_\_\_\_ (write Owner if applicable)  
Phone Number: \_\_\_\_\_  
If installed by a Plumber or Electrician, Licence No: \_\_\_\_\_  
Installation Address: \_\_\_\_\_

Tick the boxes as the item is completed/correct, put n/a if not applicable;

- The Pump is being used for an appropriate purpose for which it is intended, according to the instructions
- The Power Circuit the Pump is connected to is RCD (Safety Switch) Protected
- Barrel Unions or similar are fitted on the pipe connections for easy removal & replacement
- A Swing Check Valve is fitted to prevent back-flow
- Pipe is sized appropriately for the application (diameter and length)
- The installation is constructed so the pump can be easily removed or replaced.
- The pump is installed in accordance with National & Local Plumbing Regulations
- The Electrical Supply cable is plugged into a Power Outlet that is in accordance with the current standard of Electrical Safety Regulations AS/NZS 3000 - or the pump has been wired directly to the power circuit by a Licenced Electrician.
- The Pump has been tested with water in the sump / pit / pump-well, and operates correctly.
- The pipes and connections have been checked for leaks.
- The pump is protected from sunlight, with a suitable vented cover or enclosure.

Signed by the Installer: \_\_\_\_\_ Date Installed: \_\_\_\_/ \_\_\_\_/ \_\_\_\_

### **DANGER!!!!**

Keep the pump equipment protected from interference by pets, wildlife, children, infirm persons or incompetent persons.

### **WARRANTY**

**1 Year Warranty applies \*\***

\*\*All warranties subject to the current version of the Ascento Standard Terms & Conditions of Warranty which can be found by navigating to [www.reefe.au](http://www.reefe.au) and searching "Warranty"

# ASCENTO GROUP AUSTRALIA

ABN 20 527 073 843

37 Export St Lytton QLD 4178

PO BOX 650 Morningside QLD 4170

 [WWW.REEFE.COM.AU](http://WWW.REEFE.COM.AU)

 07 3893 5000

 [SALES@ASCENTO.COM.AU](mailto:SALES@ASCENTO.COM.AU)

VIEW RANGE!

