



## ELECTRONIC PRESSURE REGULATOR

EPR SERIES

EPR is a compact device for automatic control and protection of electric pumps up to 2,2 kW (3Hp). Equipped with an innovative outlet pressure reducing/regulating system. Therefore, in addition to the typical characteristics of traditional electronic pump controllers: integrated non-return valve, accumulation diaphragm, pressure gauge, dry-running protection, automatic reset, it allows to adjust and stabilize the outlet pressure, avoiding overloads, water hammer and, ultimately, improving end user comfort.

### APPLICATIONS

- Constant Regulated Pressure Supply for Homes
- Automatic Operation of Pressure Pumps
- Constant Regulated Pressure for Irrigation Systems
- Rain to Mains Systems
- Where cut in pressure is required. Up to 4.0 bar start pressure.

### FEATURES & BENEFITS

- Manual regulation of the constant outlet pressure with integrated adjusting tool
- Outlet pressure indicator with pointer
- Auto-setting of the start pressure linked to the outlet pressure
- Dual scale integrated pressure gauge (bar/psi)
- Integrated protection system which stops the pump in case of dry-running operation
- Anti-seize function, after 3 days of inactivity, the device starts the pump for 10 seconds in order to avoid rotor-locking
- ART function (Automatic Reset Test). If the device has been stopped due to the action of the safety system against dry operation, the ART tries to restart the pump, with a programmed sequence for when water supply has been restored
- Control Panel:
  - Yellow led light (POWER)
  - Green led light (PUMP ON)
  - Red led light (ALARM)
  - Green led light (FLOW)
  - Tactile push button for manual start
- Integrated reserve against leaks in the installation and no return valve
- Ingress Protection IP65

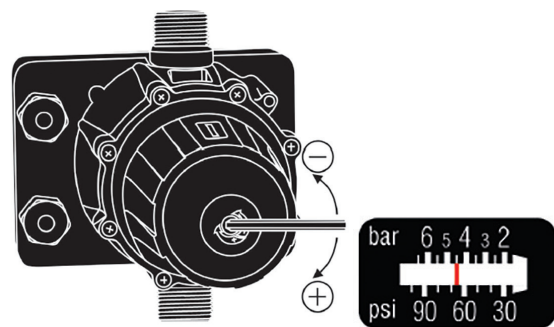

\*Relative to the outlet pressure setting. Set differential of 1.5bar

CODE	MODEL	CONNECTION	POWER 240V		CUT IN PRESSURE	MAX FLOW (L/MIN)	INLET   OUTLET	
			MAX AMPS	MAX KW			MM	IN
28384	EPR25E	10A Quick Plug	16	2.2	0.5 bar - 5.0 bar	120	25	1"
31636	EPR25E.3PS	10A 3 Pin Socket						
30271	EPR32E	10A Quick Plug						
31650	EPR32E.3PS	10A 3 Pin Socket						
31667	EPR32E.3PS	15A 3 Pin Socket				200	32	1 1/4"