

DIGITAL PRESSURE REGULATOR

DPR SERIES



DPR is a compact device for automatic control and protection of electric pumps up to 2,2 kW (3 HP). Equipped with an innovative outlet pressure reducing/regulating system. It also includes a digital display with instantaneous indication of current consumption and outlet pressure. In addition to the typical characteristics of traditional electronic pump controllers: integrated non-return valve, accumulation diaphragm, pressure gauge, dry-running protection, automatic reset, it allows the user to adjust and stabilize the outlet pressure, avoiding overloads, water hammer and, ultimately, improving end user comfort.

APPLICATIONS

- Constant Regulated Pressure Supply for Homes
- Automatic Operation of Pressure Pumps
- Constant Regulated Pressure for Irrigation Systems
- Rain to Mains Systems
- Where high cut-in pressure is required. Up to 5.0 bar start pressure.

FEATURES & BENEFITS

- Manual regulation of the constant outlet pressure with integrated adjusting tool
- Outlet pressure indicator with pointer
- Digital adjustment of the starting pressure
- Digital pressure gauge (bar or psi)
- Inner pressure transmitter and flow sensor
- Inner current sensor with instantaneous digital reading
- ART function (Automatic Reset Test). If the device has been stopped due to the action of the safety system against dry operation, the ART tries to restart the pump, with a programmed sequence for when water supply has been restored
- APR function (Anti-blocking Periodic Routine)
- Flooding protection system
- Stand-by mode
- Anti-seize function, after 3 days of inactivity, the device starts the pump for 10 seconds in order to avoid rotor-locking
- Register of operation data: controller operating hours, pump operating hours, number of operating cycles, number of connections to the power supply
- Alarm counters
- Ingress Protection IP65

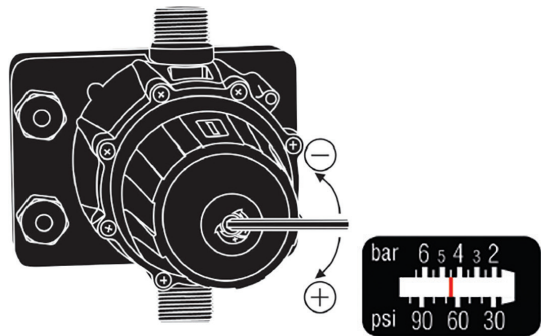

CODE	MODEL	CONNECTION	POWER 240V		CUT IN PRESSURE	MAX FLOW (L/MIN)	INLET OUTLET	
			MAX AMPS	MAX KW			MM	IN
28391	DPR25E	10A Quick Plug	16	2.2	0.5 bar - 5.0 bar	120	25	1"
31643	DPR25E.3PS	10A 3 Pin Socket						
30288	DPR32E	10A Quick Plug						
31681	DPR32E.3PS	10A 3 Pin Socket	200	32	1 ¼"			
31698	DPR32E.3PS	15A 3 Pin Socket						