



VERTICAL MULTISTAGE CENTRIFUGAL PUMP

INSTRUCTION MANUAL

MODEL: VMR5-16 | VMR10-7 | VMR10-12 | VMR20-5 |
VMR20-7

CONTENTS

Applications and Conditions	3
Definition of Model	3
Structure	4-5
Installation and Connection	6 - 10
Start-up, Operation and Maintenance	11-12
Fault Finding and Solution Chart	13-14
Important Notice	14

READ THIS MANUAL CAREFULLY BEFORE INSTALLATION AND BEFORE STARTING THE PUMP.

APPLICATIONS AND CONDITIONS

Pumps of REEFE VMR models are non-self-priming vertical multistage centrifugal pumps. Their features are high efficiency, low noise, light corrosive liquid resistance, compact structure, good appearance, small volume, light weight, easy to service, good seal performance, and covered by REEFE warranty and customer service.

i. Applications

- Pumped liquids: low viscosity, neutral, non-explosive liquids. Not containing solid particles or fibers. The liquid must not be of a corrosive nature thereby being capable of attacking the pump materials chemically.
- Boiler water supply and condensing system.
- Water treatment, filtration system.
- Food and beverage industries.
- Pressure boosting in high-rise buildings.
- Farmland irrigation, nursery irrigation and golf court irrigation.
- Industry cleaning system.
- Liquid conveying, circulation and boosting.
- Hot and cool water.

ii. Operation Conditions

- Medium temperature: Normal temperature type -15°C+70°C; Hot water type-15°C- +120°C.
- Flow: 0.4-180m³/h
- Medium pH range: pH 5-9.
- Maximum ambient temperature: +40°C.
- Maximum altitude: 1000 m; derate when higher.
- Minimum inlet pressure: Refer to catalogue for specific model of pump.

Caution: When pumping liquids with a density and/or viscosity higher than that of water, use motors with correspondingly higher outputs, if required.

DEFINITION OF MODEL

MODEL	SPECIFICATIONS
VMR5-16	Voltage input 1-240VAC; Current 12.4A Rated Head 85M; Rated Flow 1.39L/sec
VMR10-7T	Voltage input 3-415VAC; Current 6.76A Rated Head 54M; Rated Flow 2.78L/sec
VMR10-12T	Voltage input 3-415VAC; Current 8.79A Rated Head 92M; Rated Flow 2.78L/sec
VMR20-5T	Voltage input 3-415VAC; Current 11.9A Rated Head 58M; Rated Flow 5.56L/sec
VMR20-7T	Voltage input 3-415VAV; Current 15.84A Rated Head 82M; Rated Flow 5.56L/sec

STRUCTURE

The pump is mainly composed of motor, pump head, diffuser, impeller, cylinder, inlet & outlet chamber, pump shaft mechanical seal and so on. Refer to Fig.1.

- Key parts of the pump, diffuser, impeller, cylinder, shaft, are all made of stainless steel.
- Mechanical seal is a single face seal. The seal part is cemented carbides/ carbon. The support part of diffuser is made of tungsten carbide.
- Normally, pipes are connected by round flanges. Different types of connections are also available on request from the customer. See fig.2 on Page 7.

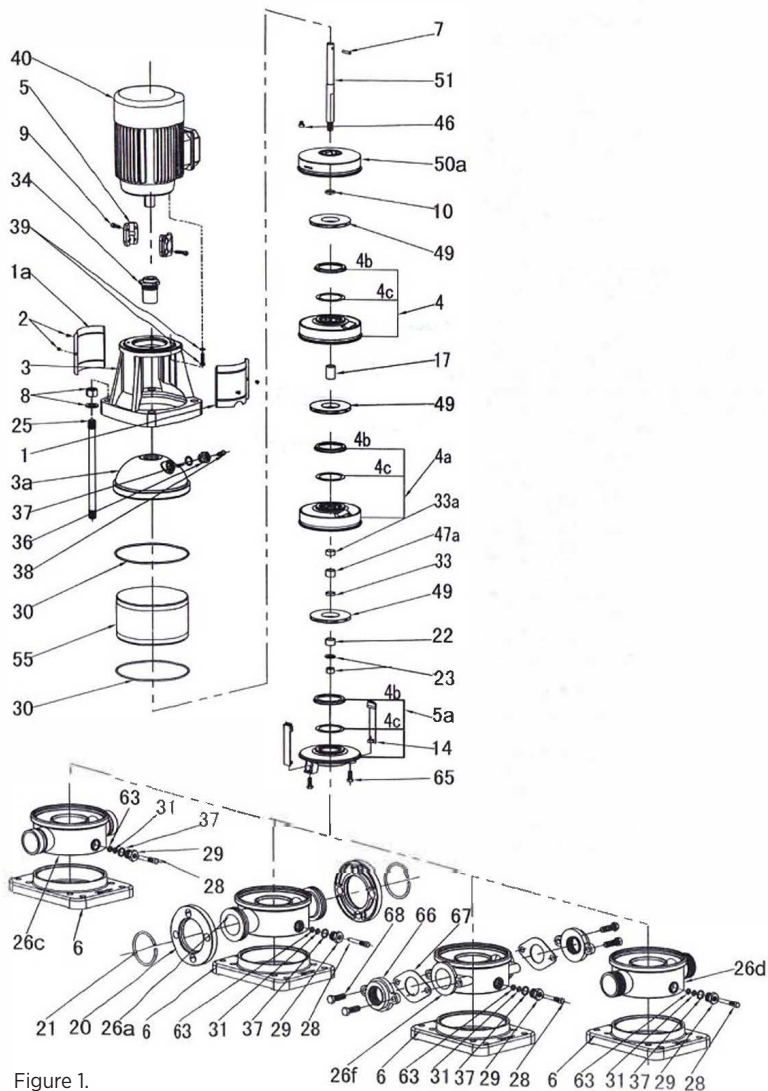

Figure 1.

POSITION	COMPONENT	POSITION	COMPONENT
1	Coupling Guard	26d	Pipe Thread Type Inlet & Outlet Chamber
1a	Coupling Guard (No nick)	26f	Oval Flange Type Inlet & Outlet Chamber
2	Screw M4x8	28	Drainage Screw M10
3	Pump Head	29	Drainage Nut
3a	Liring	30	O Ring 169x3.3
4	Diffuser	31	O Ring 8 x2.65
4a	Support Diffuser	33	Impeller Sleeve (S)
4b	Neck Ring Cover	33a	Impeller Sleeve (L)
4c	Neck Ring	34	Mechanical Seal
5	Coupling	36	Air Vent Nut
5a	Inducer	37	O Ring 16x2.65
6	Baseplate	38	Air Vent Screw
7	Shaft Plate	39	Screw, Washer
8	Nut M16 Washer 16	40	Motor
9	Hexagon socket head screw	46	Adjusting Rubber
10	Circlip cover	47a	Bearing
14	Strap	49	Impeller
17	Impeller Sleeve	50a	Top Diffuser
20	Flange	51	Shaft
21	Snap Ring	55	Cylinder
22	First Impeller Cover	63	O Ring Retainer
23	Nut M12 Waster 12	65	Bolt M8x20
25	Stay Bolt	66	Oval Flange
26a	Flange Type Inlet & Outlet Chamber	67	Oval Flange Gasket
26c	Cutting Ferrule Type Inlet & Outlet Chamber	68	Bolt M12x40

INSTALLATION AND CONNECTION

i. Handling

When lifting the entire pump with motor, follow these instructions:

- Pump with motor sizes 0.37-7kW: Lift the pump in the motor flange by means of straps or the like.
- Pump with motor sizes 11-75kW: Lift the pump by means of the motor eye bolts.

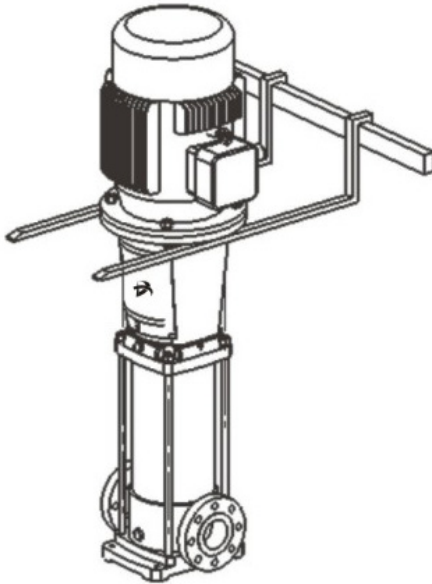

0.37-7.5kW

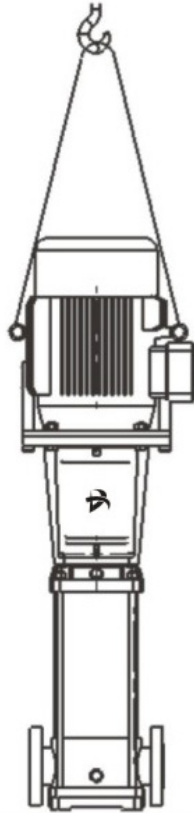

11-75kW

ii. Pump size and dimensions is as follows.

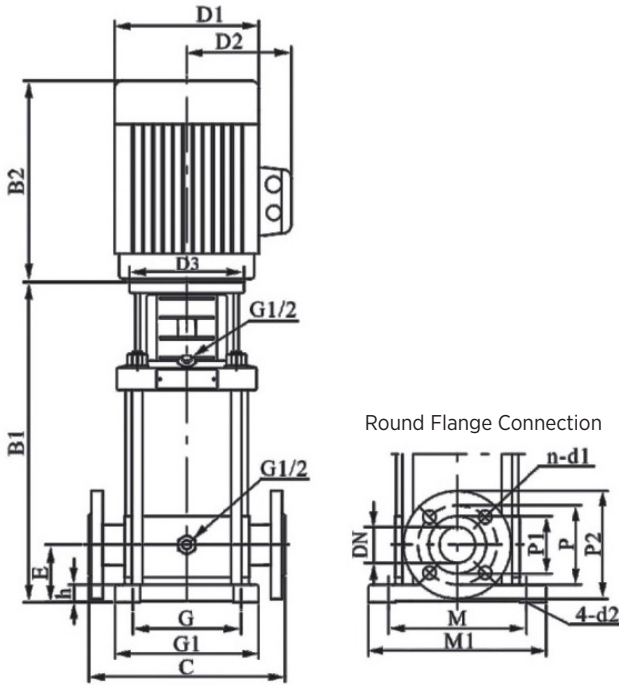
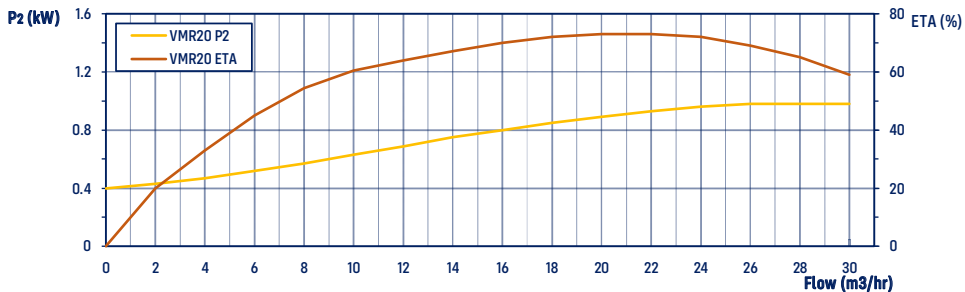
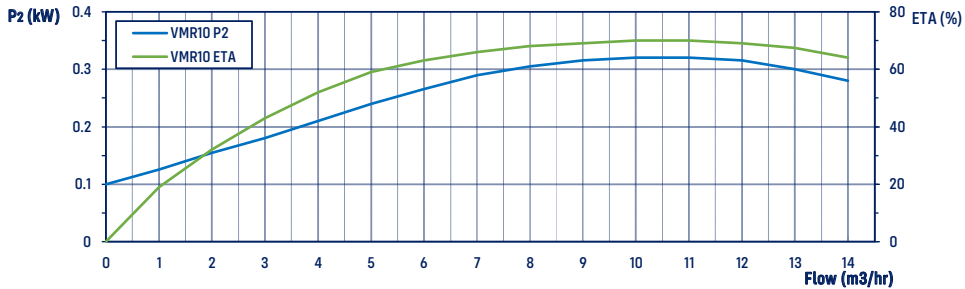
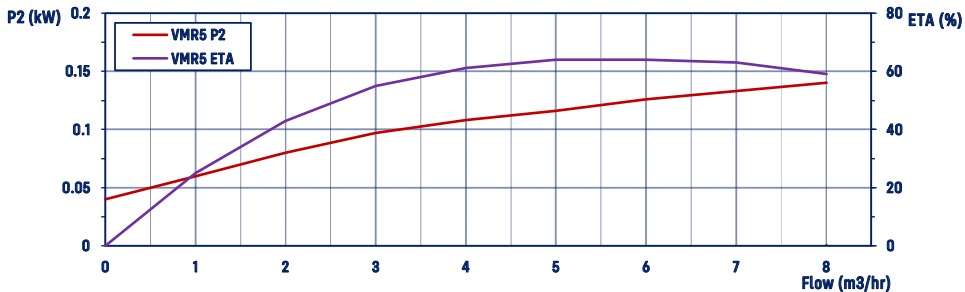
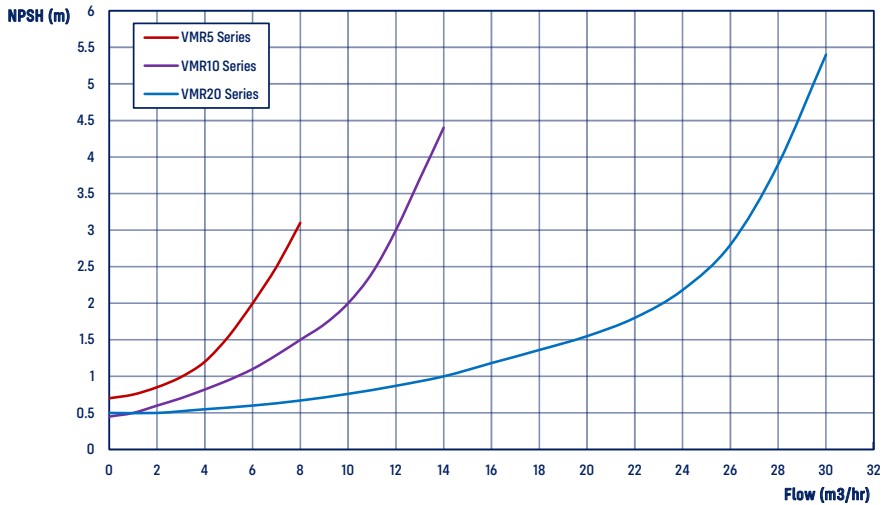

Figure 2.

MODEL	SIZE (MM)						WEIGHT (KG)
	B1	B2	B1 + B2	D1	D2	D3	
VMR5-16	684	345	1029	197	165	160	48
VMR10-7T	547	390	937	260	208	-	73
VMR10-12T	697	390	1087	260	208	-	87
VMR20-5T	562	390	952	260	208	200	76
VMR20-7T	652	390	1042	260	208	200	84

Round Flange Connection

MODEL	SIZE (MM)							
	DN	P	P1	P2	n-d1	C	E	h
VMR5-16	32	100	60	140	4 - Ø18	250	75	32
VMR10-7T	50	80	125	165	4 - Ø18	300	90	35
VMR10-12T	50	125	80	165	4 - Ø18	300	90	35
VMR20-5T	50	125	80	165	4 - Ø18	300	90	35
VMR20-7T	50	125	80	165	4 - Ø18	300	90	35



PUMP INSTALLATION

1. The pump should be sited in a well-ventilated and frost-free position. The distance between the pump-motor and other objects should be at least 150mm, to cool the motor by fan with enough air.
2. To reduce the head loss of inlet as least as possible, the inlet pipe shall be as short as possible.
3. Ensure the check valve is installed in pipeline system before the pump installation. If pump is used for boiler water supply, a check valve must be installed in the piping between pump and boiler.
4. Pump shall be installed in cement base or other similar base with suitable height. It can also be installed in fixed grounds or fixed brackets on the wall. Pay attention not to let the weight of pipe system on pump to prevent pump from damage.



Caution: When installing, the motor is not allowed to be hung upside down.

5. The arrow on the inlet and outlet chamber shows the direction of flow of liquid through the pump. Check whether the liquid can flow easily before starting the pump.
6. Before pump installation, the inlet pipeline shall be cleaned. If there are impurities in the pipe, it is necessary to install a strainer at 0.5-1m in front of the pump inlet (particularly recommended for pump with flow less than 8m³/h).
7. Air locks shall be avoided when installing the inlet pipeline. see Fig 3.

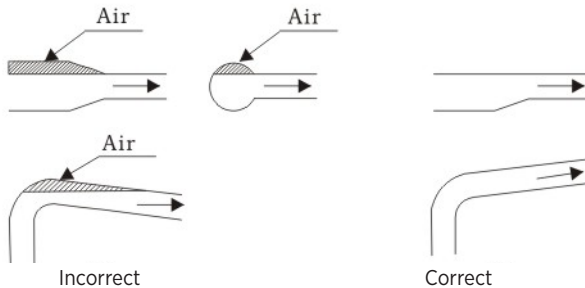

Figure 3.

8. If the outlet globe valve might be closed (or the flow is decreased to zero), a bypass shall be installed in outlet pipeline to ensure adequate lubricating and cooling water to pass the pump.

ELECTRICAL CONNECTION

1. The electrical connections should be carried out by an authorized electrician.
2. To make sure the motor is suitable for the power supply, cables of the motor must be connected to the power supply according to the Fig. on the terminal box and the motor nameplate.
3. The motor must be connected to a fast and effective motor starter to ensure that the motor will not be damaged by lack of phase, unstable voltage, or overload. The motor shall be earthed reliably.



Caution: Before taking the terminal box cover apart or dismantling the pump, make sure that the power supply is switched off.

WARNING - ELECTRICAL CONNECTION AND SAFETY DEVICES

1. The pump units should be connected to the power supply by the appropriately rated power cables according to the motor ratings.
2. The pump units should always be equipped with safety devices as required in the standards (EN 809 and/or EN 60204-1) as well as by the national rules of the country where the pump is used.
3. Despite the rules of any country, the power supply to the pump unit must be equipped with at least following electrical safety devices with appropriate ratings:
 - Emergency switch
 - Circuit breaker (as a supply disconnecting (isolating) device as well as an over-current protective device)
 - Motor overload protection

Recommendation of Electrical Connection and Safety Devices

380V (50Hz/60Hz)						
No	Power Input (kW)	Cable Connection	Input Current (A)	Cable Spec (mm)	Circuit Breaker (A)	Thermal Protector (A)
1	0.37	Y	1	0.75	5	1.2
2	0.55	Y	1.4	0.75	5	1.7
3	0.75	Y	1.8	0.75	5	2.2
4	1.1	Y	2.6	1	5	3.1
6	1.5	Y	3.5	1	10	4.2
8	2.2	Y	4.9	1.5	10	5.9
11	3	Y	6.3	1.5	10	7.6
13	4	Δ	8.2	2.5	20	9.8
15	5.5	Δ	11	2.5	20	13.2
16	7.5	Δ	15	4	20	18.0
17	11	Δ	21	4	25	25.2
18	15	Δ	29	6	32	34.8
19	18.5	Δ	35	10	40	42.0
20	22	Δ	41	16	60	49.2
21	30	Δ	55	16	60	66.0
22	37	Δ	68	25	80	81.6
23	45	Δ	82	35	100	98.4
25	55	Δ	100	70	160	120.0
26	75	Δ	134	70	160	160.8
27	90	Δ	160	90	200	192.0

The acoustic noise emission is around 85 dB (A).

1. Before opening the terminal box, please shut off the power supply to prevent power shock.

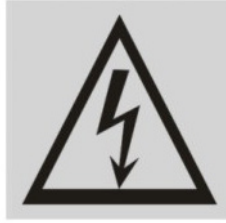

2. Before opening the coupling guards, please stop the pump first to prevent possible injury.

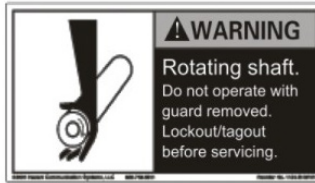

3. When installing the pump, please fix the foundation bolts vertically to prevent the pump falling over and potentially hurting people.
4. Please fill grease in the pump when it's required. For motor power is less than 5.5kW, it is free of filling grease. For motor power is equal or bigger than 5.5kW, please fill grease every 5000 running hours.



V START-UP, OPERATION AND MAINTENANCE



READ THE LABEL ON THE CYLINDER CAREFULLY BEFORE START-UP

1. Do not start the pump until it has been filled with water or liquid fully.

- Fill water in pump in inverse pouring system.
Close the pump outlet valve, release air vent screw on the pump head, and open the inlet valve slowly until stable water flows from the air vent screw, then fasten the screw. Open the check valve completely in the inlet pipeline.
- In open system, fill water in pump when liquid surface is lower than pump.



NOTICE: A CHECK VALVE SHALL BE INSTALLED IN THE INLET PIPE.

- Close the pump outlet valve, release air vent screw, and fill the liquid in pump through the air vent screw hole until the pump and inlet pipeline are filled with water fully. Fasten the air vent screw again.



CAUTION: DO NOT START THE PUMP UNTIL IT HAS BEEN FILLED WITH LIQUID FULLY AND AIR VENTED. BE CAREFUL THE DIRECTION OF THE AIR VENT SCREW HOLE. MAKE SURE THE FLOWING WATER WILL NOT HURT PERSONS OR PUMP OR ITS PARTS, ESPECIALLY, PREVENT FROM HURTING FOR THE HOT WATER APPLICATION.

2. Check the rotary direction.

Switch on the power supply and view the rotary direction by viewing the motor fan. The arrow on the pump head indicates the correct direction of rotation. That is, from the motor end, pump shall run counter-clockwise.

3. Check before pump start-up:

- Check whether the foundation bolt is fastened.
- Check whether the pump is filled with water fully.
- Check whether the voltage of power supply is correct.
- Check whether it turns correctly.
- To make sure all pipelines are connected tightly and can supply water normally.
- The valves in the inlet pipeline are completely opened and the outlet valve shall be opened slowly after the pump is started up.
- Check the operation pressure if pressure meter is installed.
- Check all the controls for normal operation. If the pump is controlled by pressure switch, check and adjust the starting pressure and stopping pressure. Check the full load current to make sure it does not surpass the max current.

4. Frequency of pump starts.

Pumps should not be started too frequently. It is suggested the pump should not be started more than 100 times per hour if the motor power is less or equal to 4kW. When motor power is larger than 4kW, pump shall not be started more than 20 times in one hour. If the pump starts and stops too frequently, the control device shall be checked and adjusted to make the pump not start and stop too frequently. Also it is necessary to check the installation.

5. Suggestion: When pump running, flow should be controlled at the range of 0.5-1.3 times of rated flow.

6. Pumps which are installed according to this installation manual will work effectively and require little maintenance.
- Mechanical seal will be adjusted automatically, the moving part and stationary part is lubricated and cooled by the transferring liquid. When replacing the mechanical seal, the user needn't disassemble the motor for power bigger than 7kW.
 - The bearing in pump is lubricated by the transferring liquid.

7. Frost Protecting

Pump can be used in the system with anti-frozen measures to water. If the pump is installed in an easily frozen place, suitable antifreeze shall be added to the transferring liquid to prevent pump from being damaged. If antifreeze is not used, pump shall be stopped when it is frozen. Pumps which are not being used should be drained.

8. The following should be checked regularly on the pump.

- Pump working and operating pressure.
- Possible leakage
- Possible motor overheating.
- Cleaning/replacement of all strainers.
- The switch off time of motor when overloaded.
- Frequency of starts and stops
- All control operation

If a malfunction is found, check the system according to "Fault finding and solution chart".

9. The pump shall be cleaned and kept appropriately when it is not used for a long time.
10. Pump shall be prevented from being corrupted and damaged in storage

FAULT FINDING AND SOLUTION CHART

Caution: Before removing the terminal box cover and before any removal/dismantling of the pump, make sure that the power supply has been switched off.

FAULT	CAUSE	SOLUTION	REMARKS
Motor does not run when started	a) Power supply failure.	a) Check power supply.	
	b) Fuses are blown.	b) Replace fuses.	
	c) Motor is overloaded.	c) Check system.	
	d) Main contacts of starter are not connected well or the coil is defective.	d) Replace motor starter.	
	e) Control circuit is defective.	e) Check control circuit.	
	f) Motor is defective.	f) Repair.	
Overload device of motor starter trips out immediately when power supply is switched on.	a) Fuses are blown.	a) Replace fuses.	In the case of d) and e), users shall not disassemble the pump by themselves
	b) Contacts of overload device are faulty.	b) Replace motor starter.	
	c) Cable connection is loose or faulty.	c) Check cables and power supply.	
	d) Motor winding is defective.	d) Replace motor	
	e) Pump mechanically blocked.	e) Check and repair pump	
Overload device trips out occasionally.	a) The setting of overload is too low.	a) Reset overload setting.	
	b) Periodic power supply faults.	b) Check power supply	
	c) Low voltage at peak times.	c) Add regulator.	
Motor starter has not tripped out, but the pump does not run.	a) Contacts of starter are not contacted well, or the coil is faulty.	a) Change motor starter	
	b) Control circuits are defective	b) Check control circuit.	
Pumped water does not flow constantly	a) Suction pipe is too small.	a) Enlarge inlet pipeline.	
	b) There is not sufficient water in pump water inlet.	b) Improve system and increase coming water.	
	c) Liquid level is low.	c) Lift liquid level.	
	d) Pump inlet pressure is too low compared with water temperature, pipeline loss and flow.	d) Improve the system and try to increase the inlet pressure.	
	e) Suction pipe is partly blocked by impurities	e) Check and clear impurities.	

FAULT	CAUSE	SOLUTION	REMARKS
Pump runs but gives no water.	a) Suction pipe is blocked by impurities.	a) Check and clean suction pipe.	
	b) Foot valve or check valve is closed.	b) Check and repair foot valve or check valve.	
	c) Leakage in suction pipe.	C) Check and repair suction pipe.	
	d) There is air in suction pipe or pump.	d) Refill liquid release air.	
Pump runs backwards when switched off.	a) Leakage in suction pipe.	a) Check suction pipe.	
	b) Foot valve or check valve is defective.	b) Check and repair foot valve or check valve.	
	c) Foot valve is blocked in opened or partly opened position.	c) Check and repair foot valve.	
	d) There is air in suction pipe.	d) Check and repair suction pipe and release air.	
Abnormal vibration or noise from pump	a) Leakage in suction pipe.	a) Check and repair suction pipe.	In the case of e) users shall not disassemble the pump by themselves.
	b) Suction pipe is too small or suction pipe is partly blocked by impurities.	b) Enlarge or check suction pipe.	
	c) There is air suction pipe or pump.	c) Refill liquid to the pump and vent air.	
	d) The comparison of the delivery head of device with delivery head of pump is very low.	d) Improve system or choose another pump model.	
	e) Pump mechanically blocked.	e) Check and repair pump.	

IMPORTANT NOTICE

1. Customers will not be advised if this manual is updated.
2. Pumps will be guaranteed for one year under normal operation with the correct model. Wearing parts are not included.
3. User shall be responsible for the damage if the disassemble the pumps by themselves in a guaranteed period.

ASCENTO GROUP AUSTRALIA

ABN 20 527 073 843

37 Export St Lytton QLD 4178

PO BOX 650 Morningside QLD 4170

 WWW.REEFE.COM.AU

 1800 807 604

 SALES@ASCENTO.COM.AU

VIEW RANGE!

