

TYPICAL SINGLE PUMP STATION

WITH HIGH LEVEL ALARM

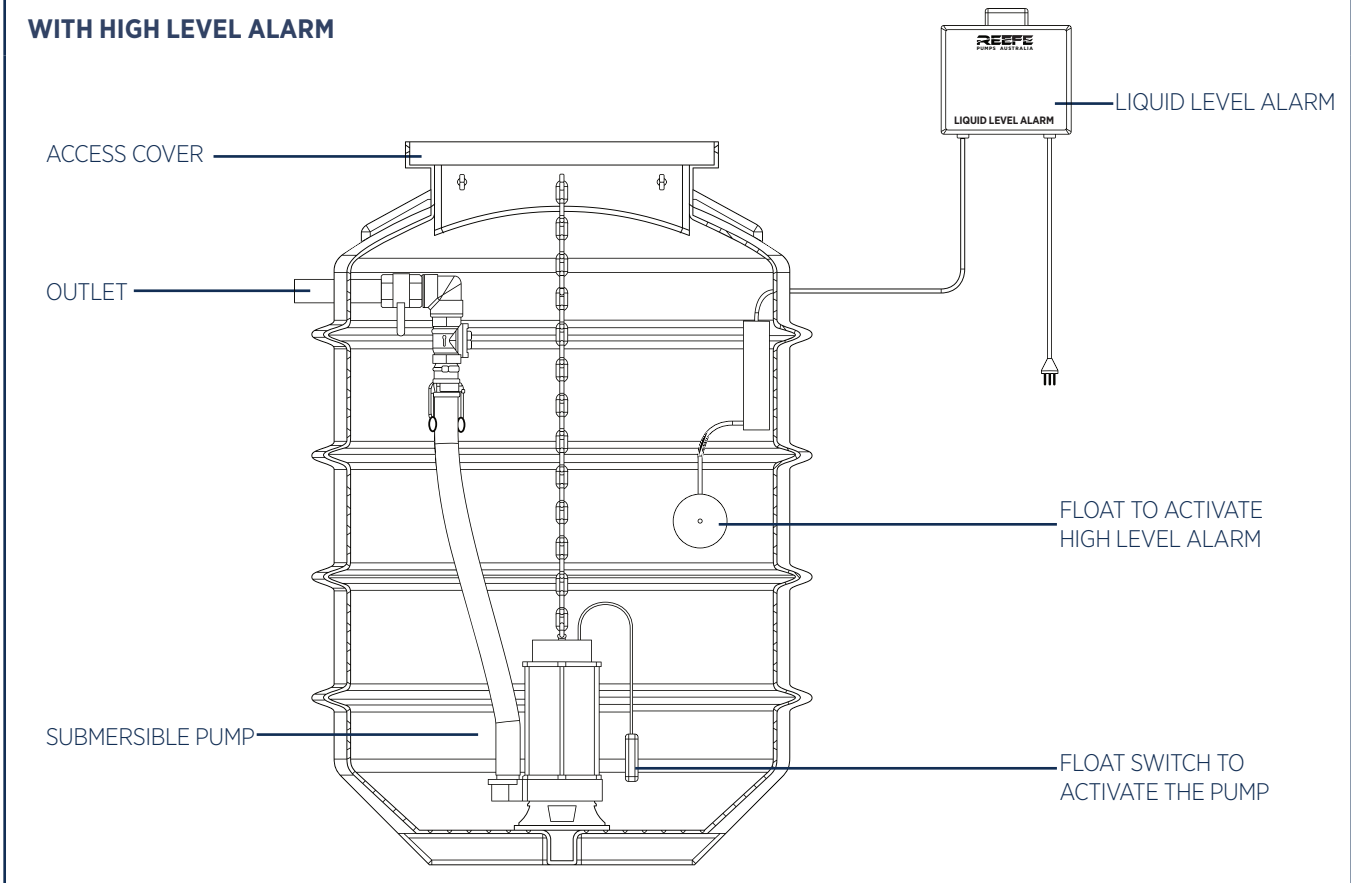

TYPICAL DUAL PUMP STATION

WITH DUAL PUMP CONTROLLER

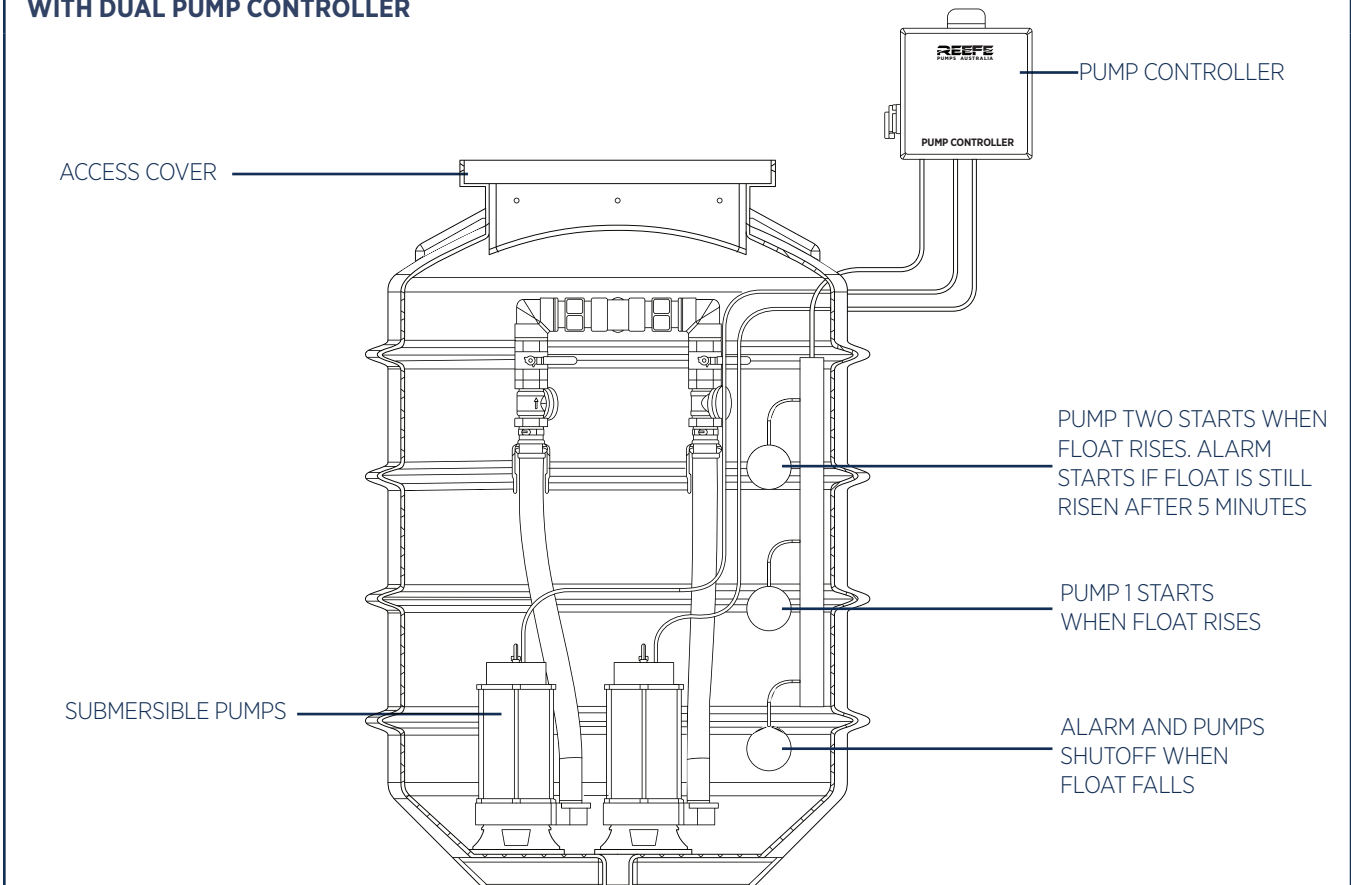

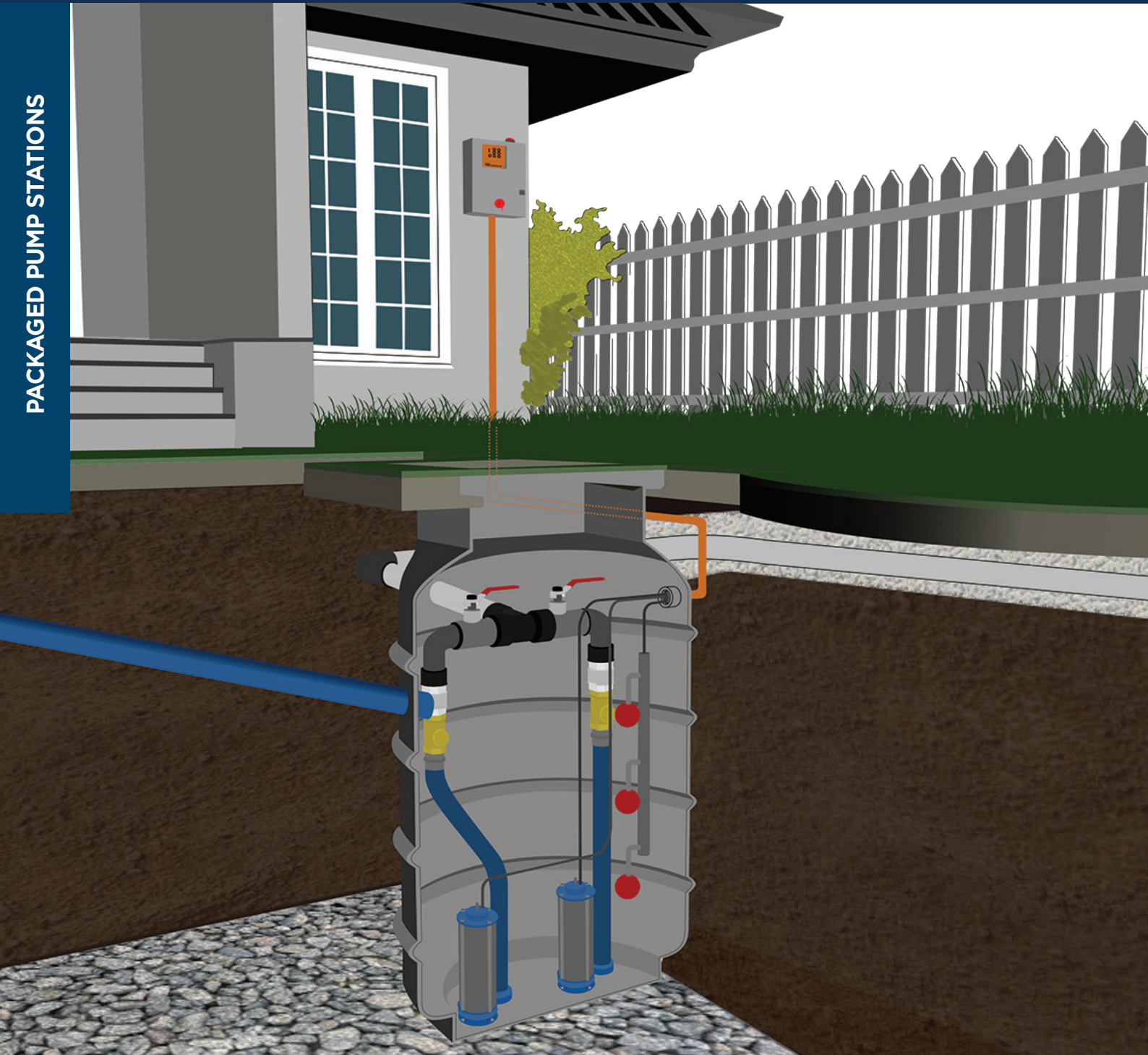

MORE OPTIONS AVAILABLE !

Ascento is able to manufacture a wide range of custom packaged pump stations to suit your exact project requirements.

- Larger pump well capacity
- Riser/s
- Larger pump
- Additional control functions
- Guide Rail systems
- Different class access cover or grate
- Complete custom pump station packages available
- Simply send your project drawings, or list out the project requirements on an email to estimating@ascento.com.au

Alternatively, scan the QR code for our online form.

Wish to discuss the options with a consultant?
Phone **1800 807 604**